



TRANSPower

NORTH ISLAND GRID UPGRADE PROJECT

AMENDED PROPOSAL

ATTACHMENT D

TECHNICAL ASSESSMENT OF MODIFIED OPTIONS

Technical Analysis of Transmission Alternatives

October 2006

Executive Summary

A number of transmission development options were considered for providing a secure power supply to the Upper North Island (the region north of Bombay). The assessment and comparison of different transmission voltages (220 kV, 330 kV, 400 kV and 500 kV), different technologies (high voltage DC and AC transmission) and implementation methods (overhead and underground) were considered in detail in Volume 2 of Transpower's Grid Upgrade Plan submitted to the Electricity Commission in September 2005.

This report presents transmission options based on the original submission in the Grid Upgrade Plan (2005), that have been further developed improving the:

- physical diversity provided by the transmission plans, making the power supply more resilient for rare but high impact disturbances
- market benefits provided by each of the options by deferring the investments required as much as possible and making the maximum utilisation of the existing transmission assets

The existing transmission system reaches its capacity by 2012 and a major new investment is required to be in place before then. Options involving building new transmission lines will utilise, for a significant portion of the lines, the same corridor as the existing Arapuni – Pakuranga 110 kV line. This will require the Arapuni – Pakuranga 110 kV line to be decommissioned 18 months prior to commissioning of the new line, resulting in reduced transmission capacity to the Upper North Island during the transition period.

Four options analysed in detail in this report include:

- building new 220 kV transmission lines into the Upper North Island;
- building a new 400 kV transmission line into the Upper North Island;
- augmenting the existing 220 kV network to defer new investment as long as possible and then building new 220 kV transmission lines into the Upper North Island when required; and
- replacing the existing 220 kV conductors on the transmission lines between Whakamaru and Otahuhu with High Temperature Conductors and then building new 220 kV transmission lines into the Upper North Island when required.

These transmission options encompass different strategic high voltage ac transmission development approaches to enhance the transmission capacity into the Upper North Island.

Option 1. 220 kV into Pakuranga and Otahuhu:

This option involves building a new 220 kV double circuit transmission line between Whakamaru and Ormiston Road (South of Otahuhu) with 220 kV underground cables from Ormiston Road, first to Pakuranga and subsequently to Otahuhu. A second 220 kV transmission line into the Upper North Island will be built when required.

The new 220 kV double circuit transmission line is assumed to have a capacity of 1237 MVA per circuit in winter. This transmission line will be series compensated in 2021 to fully utilise its transmission capacity. The compensated transmission line is expected to reach its maximum capacity by 2031, requiring an additional 220 kV double circuit transmission line to be built.

Option 2. 400 kV into Ormiston Road and 220 kV cables to Pakuranga and Otahuhu:

This option involves building a new 400 kV double circuit transmission line between Whakamaru and Ormiston Road, with 220 kV underground cables from Ormiston Road, first to Pakuranga and subsequently to Otahuhu.

The new 400 kV double circuit transmission line is assumed to have a capacity of 2700 MVA per circuit in winter. The transmission line will initially be operated at 220 kV and series compensated in 2021 to defer conversion to 400 kV as long as possible. The compensated transmission line is expected to reach its maximum capacity by 2033 and will be upgraded to operate at 400 kV by installing 400/220 kV interconnecting transformers at Whakamaru and Ormiston Road.

Option 3. 220 kV incremental development plan:

This option involves duplexing the existing Otahuhu – Whakamaru 220 kV single circuit transmission lines and re-terminating them at a point south of Auckland (SAK). 220 kV underground cables will be installed from this point to Pakuranga. The other incremental upgrades required with this option include, thermal upgrading of the Otahuhu – Whakamaru C line, providing a 220kV/110 kV interconnecting transformer at Bombay and bussing the duplexed Otahuhu-Whakamaru A & B lines at Huntly East (Ohinewai).

When the duplexed lines reach their capacity in 2020, a new 220 kV double circuit transmission line will be built between Whakamaru and Ormiston Road (South of Otahuhu) with 220 kV underground cables from Ormiston Road, first to Pakuranga and subsequently to Otahuhu. The transmission line is series compensated in 2031 to increase the utilisation of its capacity. The line will reach its full capacity in 2035, requiring building an additional 220 kV double circuit line. This transmission line will be built from Whakamaru to an intermediate point south of Auckland and a 220 kV cable will be installed from this point to a substation in Auckland¹.

Option 4. Replacing existing 220 kV conductors with High Temperature Conductors:

This option involves re-conductoring the existing 220 kV Otahuhu-Whakamaru single circuit transmission lines with duplex High Temperature Conductor (HTC) and re-terminating them at a point south of Auckland (SAK). 220 kV underground cables will be installed from this point to Pakuranga. These lines will be series compensated when required.

When the duplexed lines reach their capacity in 2023, the Otahuhu-Whakamaru C line will be re-conductored with HTC (duplex) and series compensated on both its line sections. In 2029, a new 220 kV double circuit transmission line will be built between Whakamaru and Ormiston Road with underground cables from there to Pakuranga and Otahuhu. This new 220 kV line will be series compensated, when required.

The transmission loss as well as the reactive power support requirement under this transmission option is considerably higher compared to the other options described above.

¹ For the purposes of this study, this has assumed to be at Otahuhu but it may be some other more appropriate substation in Auckland.

Reactive support is planned to meet reactive power losses and ensure voltage stability of the power system. A 5% load margin is allowed to take into account any modelling uncertainties. Dynamic reactive power support is planned such that sufficient reserves are maintained to cover the worst transmission contingency whether the Otahuhu Combined Cycle generator is in or out of service.

Table of Contents

1	INTRODUCTION	7
2	OVERVIEW OF TRANSMISSION SUPPLY INTO THE UPPER NORTH ISLAND	10
3	GENERATION AND DEMAND SCENARIOS	16
3.1	Generation Development	16
3.2	Slack Generator/bus	17
3.3	Demand Forecast	17
3.3.1	Seasonal variation of demand and generation	18
4	ASSUMPTIONS AND METHODOLOGY	20
4.1	General Assumptions	20
4.2	Security Criteria	20
4.2.1	Contingencies considered	20
4.2.2	Steady State Planning Criteria	21
4.2.3	Dynamic Analysis	21
4.3	Planning Horizon	21
4.4	Methodology for the analysis	21
4.4.1	Transmission Plan	21
4.4.2	Transfer Limit	22
4.4.3	Reactive Power Support	23
5	OVERVIEW OF THE TRANSMISSION OPTIONS	25
5.1	Common Augmentations	26
6	ANALYSIS OF THE RESULTS	32
6.1	Summary of the analysis	32
6.2	Option 1: 220 kV into Pakuranga and Otahuhu	34
6.3	Option 2: 400 kV into Ormiston Road and 220 kV cables to Pakuranga and Otahuhu (late conversion to 400 kV)	40
6.4	Option 3: Incremental development plan - Duplexing of Whakamaru-Otahuhu A & B lines	46
6.5	Option 4: Replacing Existing 220 kV conductors with High Temperature Conductors	53
6.6	Transmission Losses	61
6.7	Reactive Plan	62
6.7.1	Dynamic Reactive Requirement for Transmission line contingency	62
6.8	Short Tem Augmentation Projects	65
7	CONCLUSION	68
APPENDIX A	SUBSTATION THREE-LETTER CODES	70
APPENDIX B	ELECTRICAL PARAMETERS (OPTIONS 1-4)	71
APPENDIX C	UPPER NORTH ISLAND DEMAND FORECAST DATA	75
APPENDIX D	ENVIRONMENTAL AND PROPERTY RISKS	76

APPENDIX E	DATA FOR GRAPHS AND STUDY CASES.....	80
APPENDIX F	OTHER TRANSMISSION OPTIONS CONSIDERED	81
	Overview of the Transmission Options	81
	Option 5.1 – 400 kV into Otahuhu (early conversion to 400 kV).....	81
	Option 5.2 – 400 kV into Otahuhu (defer conversion to 400 kV)	87
	Option 6 – 220 kV into Otahuhu	93
	Option 7.1: 400 kV into Pakuranga and Otahuhu (early conversion to 400 kV)	99
	Option 7.2 : 400 kV into Pakuranga and Otahuhu (defer conversion to 400 kV).....	105
	Option 8: 400 kV into Ormiston Road, 220 kV into Pakuranga and Otahuhu (early conversion to 400 kV)	111
APPENDIX G	TRANSMISSION LOSSES (OPTIONS 5-8).....	117
APPENDIX H	REACTIVE PLAN (OPTIONS 5-8).....	118
APPENDIX I	ELECTRICAL PARAMETERS FOR PRELIMINARY STUDIES (OPTIONS 5-8)....	120

1 Introduction

This report describes the technical assessment of alternatives for augmenting the transmission capacity into the Upper North Island (UNI) to ensure adequate security of supply out to 2042. The results of the analysis are summarised in the form of a timed development plan for each transmission alternative. The timings of the planned transmission developments are based on Electricity Commission’s prudent demand forecast.

The scope of this report is limited to:

- steady state analysis of the North Island Power System to ensure that the power system would remain in a satisfactory state following any single credible contingency event occurring on the core grid, whether Otahuhu Combined Cycle generator (OTC) is in or out of service (ie n-g-1).
- the power transmission to the UNI (including cables from Otahuhu or Pakuranga to Penrose) and does not address security issues in the intra-Auckland region or the remainder of North Island. For these areas, the analysis assumes the development plans are as described in the Annual Planning Report – 2006, Sections 5 to 13².

Reactive power support is developed to ensure stable operation of the power system (in particular with regard to the voltage stability of the system) up to a demand level exceeding 5% of the forecast demand in each year. This 5% stability margin (load margin) in the UNI allows for any modelling inaccuracies. The plans address the reactive requirement in the UNI and at Huntly (due to its importance in meeting the reactive requirement of the UNI).

Four transmission options were analysed in detail for enhancing the security of supply into the UNI as follows:

Options Short listed for Further Study		
Option #	Title	Requires
1	220 kV into Pakuranga and Otahuhu	<ul style="list-style-type: none"> • Building a new 220 kV double circuit transmission line between Whakamaru and Ormiston Road and 220 kV underground cables from Ormiston Road initially to Pakuranga and later to Otahuhu ; • Installing series compensation on the transmission line, when required, to increase the transfer capacity to UNI; • Building an additional 220 kV double circuit transmission line when the transfer capacity to the UNI is exhausted; This transmission line will be built from Whakamaru to an intermediate point south of Auckland and a 220 kV cable will be installed from this point to a substation in Auckland³.
2	400 kV into Ormiston Road, 220 kV into Pakuranga and	<ul style="list-style-type: none"> • Building a new 400 kV double circuit transmission line between Whakamaru and Ormiston Road and 220 kV underground cables from Ormiston Road initially to Pakuranga and later to Otahuhu.

² The development plans described in the Annual Planning Report, 2006, cover a shorter timeframe only up to 2020.

³ For the purposes of this study, this has assumed to be at Otahuhu but it may be some other more appropriate substation in Auckland.

	Otahuhu.	<ul style="list-style-type: none"> • The transmission line will initially be operated at 220 kV; • Installing series compensation on the new transmission line to increase the transfer capacity to UNI first; • Converting the transmission circuits to 400 kV operation when the capacity of the series compensated circuits reach their capacity limits under 220 kV operation.
3	220 kV incremental development plan.	<ul style="list-style-type: none"> • Duplexing the Otahuhu – Whakamaru A & B single circuit transmission lines; • Re-terminating the Otahuhu-Whakamaru A and B transmission lines to a point south of Auckland with 220 kV cables from this point to Pakuranga⁴; • Bussing the Otahuhu-Whakamaru A and B transmission lines at Huntly East; • When required, build a new 220 kV double circuit transmission line between Whakamaru and Ormiston Road and 220 kV underground cables from Ormiston Road initially to Pakuranga and later to Otahuhu ; • Installing series compensation on the transmission line, when required, to increase the transfer capacity to UNI; • Building an additional 220 kV double circuit transmission line between Whakamaru and an intermediate point south of Auckland and installing 220 kV cables form the intermediate point to a substation in Auckland, when the transfer capacity to the UNI is exhausted.
4	Replacing Existing 220 kV conductors with High Temperature Conductors	<ul style="list-style-type: none"> • Replacing the existing conductors on Otahuhu-Whakamaru A & B lines with duplex High Temperature Conductors and terminating them at a point south of Auckland with 220 kV cables from there to Pakuranga; • Installing series compensation the lines and bus them at Huntly East when required; • Replacing the existing conductors on Otahuhu-Whakamaru C line with duplex High Temperature Conductors and series compensating the lines when required; • Building a new 220 kV double circuit transmission line from Whakamaru to Ormiston Road with 220 kV cable from there to Pakuranga and later to Otahuhu; • Installing series compensation the new line, when required.

These four options were short-listed for further detailed analysis because they:

- represent different strategic approaches which could potentially improve the supply security to the UNI
- provide sufficient route diversity for supplying the region

Other transmission options that were studied during the preliminary phase, but not short-listed, include:

Options Not Considered in Detail

⁴ The line section from Otahuhu to Ormiston Road will **not** be duplexed and will be disconnected.

NORTH ISLAND GRID UPGRADE PROJECT – AMENDED PROPOSAL
ATTACHMENT D – TECHNICAL ASSESSMENT OF MODIFIED OPTIONS

Option	Title	Requires
5	400 kV into Otahuhu	<ul style="list-style-type: none"> • Building a new 400 kV double circuit transmission line between Whakamaru and Ormiston Road and 400 kV underground cables from Ormiston Road to Otahuhu. • The transmission line would initially operate at 220 kV with sub options as follows:
	Option 5.1	<ul style="list-style-type: none"> ○ Converting to 400 kV operation first and then installing series compensation to increase the transfer capacity into UNI when required;
	Option 5.2	<ul style="list-style-type: none"> ○ Installing series compensation to increase the transfer capacity to UNI first and then converting to 400 kV operation when required;
6	220 kV into Otahuhu.	<ul style="list-style-type: none"> • Building a new 220 kV double circuit transmission line between Whakamaru and Ormiston Road and 220 kV underground cables from Ormiston Road to initially Otahuhu and later to Pakuranga. • Installing series compensation on the transmission line, when required, to increase the transfer capacity to the UNI. • Building an additional 220 kV double circuit transmission line between Whakamaru and Ormiston Road when the transfer capacity to the UNI is exhausted;
7	400 kV into Pakuranga and Otahuhu.	<ul style="list-style-type: none"> • Building a new 400 kV double circuit transmission line between Whakamaru and Ormiston Road and 400 kV underground cables from Ormiston Road initially to Pakuranga and later to Otahuhu. • The transmission line would initially operate at 220 kV with sub options as follows:
	Option 7.1	<ul style="list-style-type: none"> ○ Converting to 400 kV operation first and then installing series compensation to increase the transfer capacity into the UNI when required;
	Option 7.2	<ul style="list-style-type: none"> ○ Installing series compensation to increase the transfer capacity to the UNI first and then converting to 400 kV operation when required;
8	400 kV into Ormiston Road, 220 kV into Pakuranga and Otahuhu (Early Conversion to 400 kV) ⁵	<ul style="list-style-type: none"> • Building a new 400 kV double circuit transmission line between Whakamaru and Ormiston Road and 220 kV underground cables from Ormiston Road initially to Pakuranga and later to Otahuhu. • The transmission circuits would initially operate at 220 kV and converted to operate at 400 kV when required by building 400 kV/220 kV substations at Ormiston Road and Whakamaru. • Installing series compensation on the 400 kV transmission line, when required, to increase the transfer capacity into the UNI;

The development plans for these options are shown in Appendix F .

⁵ Late conversion of the transmission circuits to 400 kV is analysed in detail as Option 2

2 Overview of Transmission Supply into the Upper North Island

The Upper North Island is primarily supplied from the south through six 220 kV circuits, involving:

- three circuits from Huntly to Otahuhu (the western path); and
- three circuits from Whakamaru to Otahuhu (the central path).

The Upper North Island is also supplied by two smaller 110 kV circuits from Bombay and the 110 kV circuit from Arapuni to Pakuranga⁶ (though their contribution is minor compared to the 220 kV circuits).

Figure 2-1 shows the existing transmission system into the Upper North Island from the south.

⁶ The 110 kV Arapuni-Pakuranga transmission line is also scheduled for decommissioning 18 months prior to the commissioning of any new transmission line, as the new line will utilise some of the Arapuni-Pakuranga line route.

NORTH ISLAND GRID UPGRADE PROJECT – AMENDED PROPOSAL
ATTACHMENT D – TECHNICAL ASSESSMENT OF MODIFIED OPTIONS

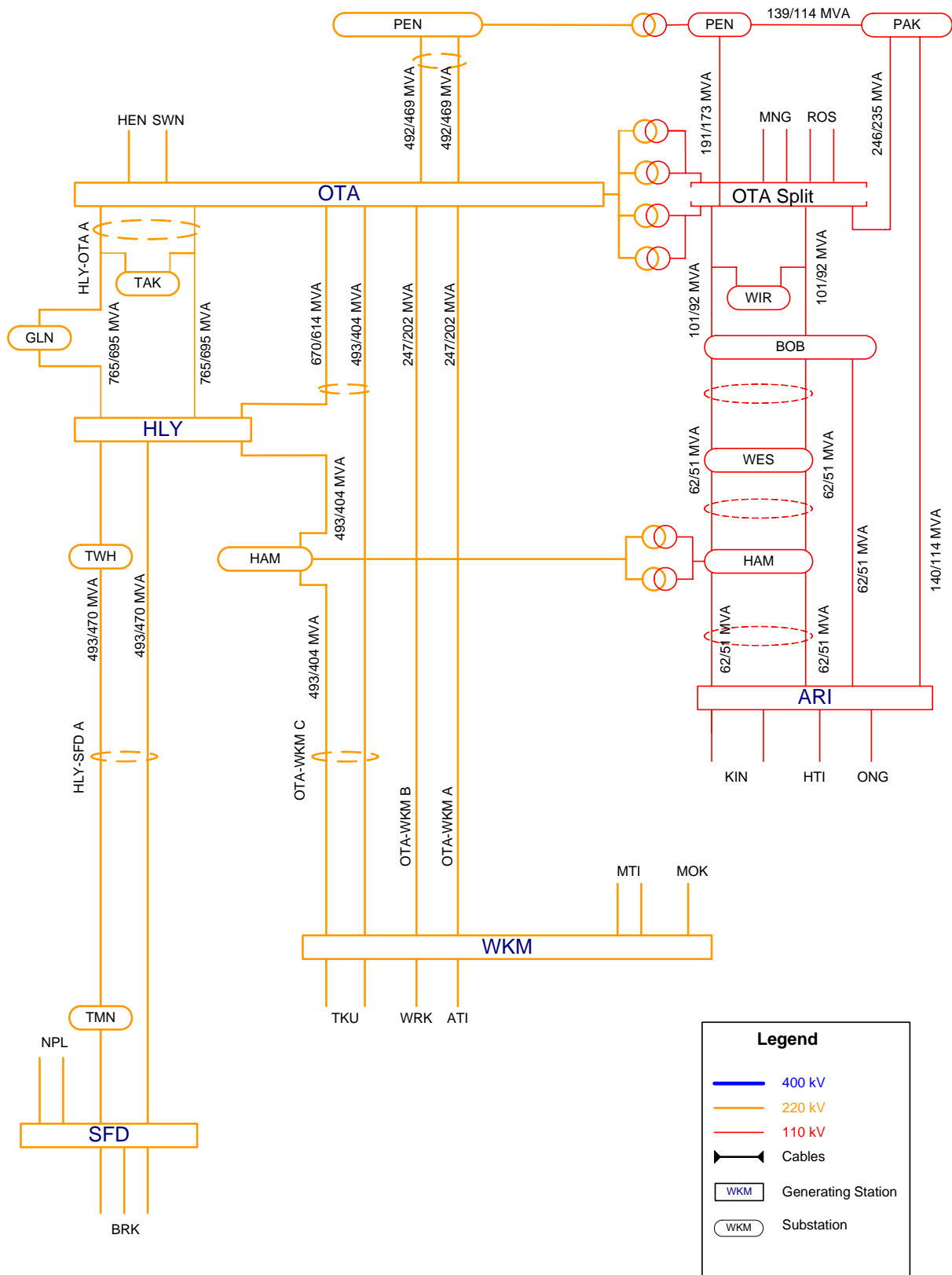

Figure 2-1 Existing Transmission System into the UNI from the south

Table 2-1 lists ratings of the existing 220 kV circuits supplying the Upper North Island from the south.

Line	Circuit	Conductor	Conductor Winter/Summer Rating
Huntly-Otahuhu A	Huntly-Takanini-Otahuhu 2	HLY to OTA <ul style="list-style-type: none"> • 53 km of 2 x Zebra @ 75⁰C • 23 km of 2 x Chukar @ 75⁰C TAK- tee <ul style="list-style-type: none"> • 0.064 km of 1 x Chukar @ 75⁰C 	HLY to OTA <ul style="list-style-type: none"> • 765¹/695 MVA • 1,236/1,124 MVA TAK- tee <ul style="list-style-type: none"> • 618/562 MVA
	Glenbrook-Huntly 1	<ul style="list-style-type: none"> • 75 km of 2 x Zebra @ 75⁰C 	<ul style="list-style-type: none"> • 765²/695 MVA
	Glenbrook-Takanini-Otahuhu 1	GLN to OTA <ul style="list-style-type: none"> • 22 km of 2 x Zebra @ 75⁰C • 23 km of 2 x Chukar @ 75⁰C TAK- tee <ul style="list-style-type: none"> • 0.26 km of 1 x Chukar @ 75⁰C 	GLN to OTA <ul style="list-style-type: none"> • 765³/695 MVA • 1,236/1,124 MVA TAK- tee <ul style="list-style-type: none"> • 618/562 MVA
Otahuhu-Whakamaru A	Otahuhu – Whakamaru 1	<ul style="list-style-type: none"> • 191 km of 1 x Goat @ 50⁰C 	<ul style="list-style-type: none"> • 247/202 MVA
Otahuhu-Whakamaru B	Otahuhu – Whakamaru 2	<ul style="list-style-type: none"> • 191 km of 1 x Goat @ 50⁰C 	<ul style="list-style-type: none"> • 247/202 MVA
Otahuhu-Whakamaru C	Huntly-Otahuhu 1	<ul style="list-style-type: none"> • 73 km of 2 x Goat @ 80⁰C • 17 km of 2 x Zebra @ 75⁰C 	<ul style="list-style-type: none"> • 670/614 MVA • 765/695 MVA
	Hamilton-Huntly 1	<ul style="list-style-type: none"> • 32 km of 2 x Goat @ 50⁰C • 5 km of 2 x Goat @ 71⁰C • 17 km of 2 x Zebra @ 75⁰C 	<ul style="list-style-type: none"> • 493/404 MVA • 626/564 MVA • 765/695 MVA
	Hamilton-Whakamaru 1	<ul style="list-style-type: none"> • 85 km of 2 x Goat @ 50⁰C • 5 km of 2 x Goat @ 71⁰C 	<ul style="list-style-type: none"> • 493⁴/404 MVA • 626/564 MVA
	Otahuhu – Whakamaru 3	<ul style="list-style-type: none"> • 118 km of 2 x Goat @ 50⁰C • 73 km of 2 x Goat @ 80⁰C 	<ul style="list-style-type: none"> • 493⁵/404 MVA • 671/615 MVA
Notes:			
1. HLY-TAK-OTA-2 has a station component limit that limits its winter rating to 760 MVA			
2. GLN-HLY-1 has a station component limit that limits its winter rating to 762 MVA			
3. GLN-TAK-OTA-1 has a station component limit that limits its winter rating to 762 MVA			
4. HAM-WKM-1 has a station component limit that limits its winter rating to 477 MVA			
5. Otahuhu-Whakamaru 3 has a station component limit that limits its winter rating to 457 MVA.			

Table 2-1 - 220 kV Circuit Ratings (Supplying UNI from the South)

In the present transmission system outages on the 220 kV transmission circuits, which constraints the power flow to UNI are as follows:

- An outage of the 220 kV Otahuhu-Whakamaru 3 circuit during high load periods will overload the 220 kV Otahuhu-Whakamaru 1 and 2 circuits for high generation south of Whakamaru and high HVDC transfer north.

This contingency also increases the transmission through Bombay – Hamilton 110 kV circuits, bringing them closer to their thermal capacity;

- An outage of the 220 kV Huntly-Takanini-Otahuhu 2 or Huntly-Glenbrook 1 circuits during high load periods will overload the 220 kV Huntly-Otahuhu 1 circuit for high Huntly generation;

- An outage of a major generating unit in the Auckland region, coupled with an outage of the 220 kV Huntly-Takanini-Otahuhu circuit, will overload the Hamilton-Bombay 110 kV circuit⁷.

The transmission loading due to the first two outages described above is exacerbated if a major generating unit (e.g., Otahuhu combined cycle plant) is also out of service.

Planned transmission developments such as the Huntly East substation, thermal upgrade of the Otahuhu-Whakamaru 1 & 2 circuits and the Bombay line splitting scheme, ensure sufficient transmission capacity will be available for securely supplying the UNI demand until 2011.

Transfer to UNI is dependent on

- the generation from Huntly and the transmission capacity available between Huntly and Otahuhu
- generation from Whakamaru and South of Whakamaru and the transmission capacity available between Whakamaru and Otahuhu

When the load in the UNI is increased, careful balancing of the generation from Huntly and Whakamaru is required to maximise the power transfer to UNI while utilising the maximum available capacity of the transmission circuits (Refer to Section 4.4.2 for further details)

During summer months, because of the lower thermal ratings and possible operating constraints on Huntly generation, the transmission capacity to the UNI is limited by the transmission constraints between Whakamaru and Otahuhu.

Table 2-2 lists the generation presently available for the UNI and Huntly. Generators generally have a lower level of availability compared to transmission lines and may not be available to relieve loading on the 220 kV circuits into the UNI during a contingency.

Generator	Power Output	Reactive Output
Southdown G1	35 MW	26 Mvar
Southdown G2	35 MW	26 Mvar
Southdown G3	30 MW	18.30Mvar
Otahuhu B	360 MW	249 Mvar
Glenbrook G3	30 MW	37 Mvar
Huntly UN1	250 MW	121 Mvar
Huntly UN2	250 MW	121 Mvar
Huntly UN3	250 MW	121 Mvar
Huntly UN4	250 MW	121 Mvar
Huntly G6	40 MW	38 Mvar

⁷ A line splitting scheme to mitigate the overloading during high summer conditions is being installed at Bombay in 2008

Total Generation	1530 MW	878.3 Mvar
-------------------------	----------------	-------------------

Table 2-2: Present Generation in Upper North Island

Table 2-3 lists the reactive support available for the Upper North Island (static reactive support from capacitors and dynamic reactive support from synchronous compensators).

Location	Capacitor Banks
Static	
Albany 110 kV	1 x 50 Mvar
Albany 11 kV	2 x 30 Mvar
Henderson 220 kV	1 x 75 Mvar
Henderson 11 kV	2 x 30 Mvar
Hepburn Road 110 kV	1 X 50 Mvar
Kaikohe 11 kV	4 x 5 Mvar
Otahuhu 110 kV	2 x 50 Mvar
Otahuhu 220 kV	1 x 100 Mvar
Otahuhu 11 kV	3 x 30 Mvar
Penrose 110 kV	1 X 50 Mvar
Penrose 220 kV	1 x 75 Mvar
Wairau Road 33 kV	2 x 18 Mvar
Total Static Reactive Support	766 Mvar
Dynamic	
Marsden	1 x 60 Mvar
Otahuhu 110 kV	2 x 33 Mvar
Total Dynamic Reactive Support	126 Mvar

Table 2-3: Reactive Support Presently Available in the Upper North Island

- Reactive support in the transmission system is required for
- (a). supplying the reactive power consumed by the loads⁸
 - (b). supplying the reactive power losses in the transmission circuits. All of this requirement is generally met by the reactive support installed at the transmission substations.

⁸ A significant amount of this reactive power demand is met through the capacitors connected to the distribution system

Dynamic reactive power support is required for meeting the reactive demand variation during system transients, so that system voltages are maintained and the power system remains stable.

3 Generation and Demand Scenarios

3.1 Generation Development

The generation development scenario used in the studies is based on the ‘Large Hydro’ scenario described in the Initial Statement of Opportunities (SOO), July 2005 published by the Electricity Commission. However, it excludes any generation north of Whakamaru from that scenario⁹. Table 3-1 shows the future generation development scenario assumed for the analysis.

All new generation is dispatched at 100% capacity, except for wind generation south of Whakamaru, which is dispatched at 33% capacity due to its intermittent and non-dispatchable characteristics. Wind generators in the UNI are not dispatched.

Year	Location	Type	Output
2004	Te Apiti (Central)	Wind	90 MW
2005	Wairakei Extension (Waikato)	Geothermal	14 MW
2006	Kiwi Cogen (Taranaki)	Gas	15 MW
2006	Southdown ¹⁰ (Auckland)	Gas	50 MW
2007	Huntly E3P (Waikato)	Gas	374 MW
2008	Makara Wind Farm (Wellington)	Wind	24 MW
2009	Tararua Wind Farm Expansion (Central)	Wind	100 MW
2012	Rotokawa II (Waikato)	Geothermal	100 MW
2012	Wairakei Geothermal (Waikato)	Geothermal	180 MW
2013	Kawerau (Bay of Plenty)	Geothermal	100 MW
2014	New Plymouth (Taranaki)	Coal	300 MW
2014	Mohaka (Hawkes Bay)	Hydro	75 MW
2018	Rotokawa III (Waikato)	Geothermal	100 MW
2019	Ngaruroro Scheme (Hawkes Bay)	Hydro	134 MW
2019	Whirinaki River (Bay of Plenty)	Hydro	25 MW
2021	Atiamuri (Bay of Plenty)	Geothermal	50 MW
2021	Horohoro (Bay of Plenty)	Geothermal	40 MW
2021	Mangakaino (Waikato)	Geothermal	40 MW

⁹ The generation scenario used in this analysis is the same as that used by the Electricity Commission for assessing transmission alternatives: “Transmission Augmentations into Auckland: Technical Analysis of Transpower’s Proposal and Short short-listed Alternatives-Part I” by System Studies Group NZ Limited, April 2006”

¹⁰ The Generator is not considered in the load flow analysis, but the transfer limit is adjusted to consider the impact of this generator. Being in Auckland, this increases the transfer limit by 50 MW.

Year	Location	Type	Output
2022	Pohipi (Waikato)	Geothermal	20 MW
2022	Belmont Wind Farm (Wellington)	Wind	120 MW
2023	Makara Wind Farm Expansion (Wellington)	Wind	100 MW
2023	Wanganui Coast Wind Farm (Taranaki)	Wind	100 MW
2024	Kawerau (Bay of Plenty)	Geothermal	50 MW
2024	Tauhara (Waikato)	Geothermal	15 MW
2024	Mangawhero to Wanganui Diversion (Central)	Hydro	60 MW
2026	Ngatamariki (Waikato)	Geothermal	30 MW
2027	Mokai III (Waikato)	Geothermal	100 MW
2028	Kawerau (Bay of Plenty)	Geothermal	50 MW
2029	Rotoma (Bay of Plenty)	Geothermal	40 MW
Total Generation Development in North Island			2496 MW

Table 3-1: Generation Development in the North Island

New generation plants are assumed to be capable of providing reactive power equivalent to at least 50% of real power output.

3.2 Slack Generator/bus

The HVDC link at Haywards is considered a good location for the slack generator and is modelled as one of the slack generators. For the purposes of these studies the HVDC link capacity is assumed to be 1400 MW as a proxy for new generation south of Bunnythorpe and/or a possible upgrade of the HVDC link capacity¹¹.

An additional slack generator is also modelled at Whakamaru to make up any generation shortfall in excess of the 1400 MW assumed for the HVDC link. The reactive power limit for the slack generator at Whakamaru is considered to be 50% of the active power generated.

3.3 Demand Forecast

The demand forecast¹², used in the planning assumptions was supplied by the Electricity Commission and represents their view of a prudent peak demand forecast for the Upper North Island as one region. The forecast is indexed to the 2005 energy demand forecast as published in the Electricity Commission's Initial Statement of Opportunities released in July 2005. Full details of the prudent peak demand forecasting methodology can be found in the

¹¹ A proposal to increase the HVDC link capacity to 1400 MW was submitted to the Electricity Commission in the Grid Upgrade Plan 2005, Volume 3.

¹² The transmission development plans were initially developed using the Transpower 2005 high demand forecast. The plans were later adjusted to match the EC prudent demand forecast by aligning the years where a given level of demand is forecast. This resulted in advancing the planned developments by approximately one year.

Electricity Commission's report, Draft Regional Peak Demand Forecast dated 28 August 2006

The studies described in this report are based on the winter prudent demand forecast, unless otherwise specifically stated.

3.3.1 Seasonal variation of demand and generation

Three different seasons have been considered for the analysis to represent the distinct demand patterns. They are:

- a). Winter;
- b). Summer; and
- c). High Summer

The prudent demand forecasts for the three different seasons is shown in Figure 3-1

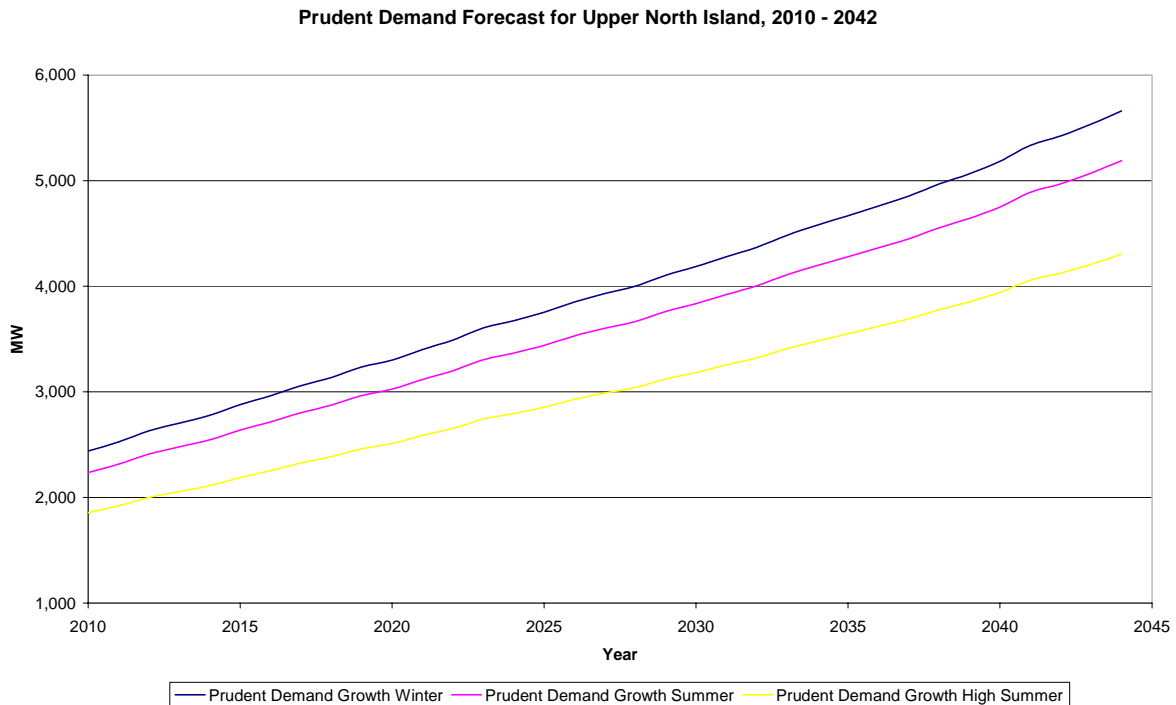

Figure 3-1: Prudent demand forecasts for Upper North Island 2010-2042

The winter peak cases represent demand over the winter period from 10 May to 19 October. The power factors assumed in the studies for the winter demand forecast are as follows:

- Upper North Island – 0.986 lagging
- North Island – 0.979 lagging

The summer peak cases represent demand over the summer period from 20 October to 9 May. The power factors assumed in the studies for the summer demand forecast are as follows:

- Upper North Island – 0.989 lagging
- North Island – 0.978 lagging

The generation scenario for the summer peak cases is the same as that used for the winter peak cases except that 1 x 250 MW unit at Huntly is assumed to be unavailable due to maintenance.

The high summer peak cases represent demand from 1 January to 28/29 February when high summer temperatures can limit Huntly generation due to river heating constraints. High loads in the Auckland area, especially during early afternoon compound this problem. The power factors assumed in the studies for the high summer demand are as follows:

- Upper North Island – 0.97¹³ lagging
- North Island – 0.967 lagging

The generation scenario used for the high summer peak cases is the same as that used for the winter peak cases except that Huntly is limited to:

- 1 x 250 MW (unit with a cooling tower);
- 2 x 80 MW (units without cooling towers); and
- 1 x 40 MW (the new P40 unit).
- Huntly E3P is also assumed to be in service.

¹³ The assumed power factor is based on the System Operator report titled “Procurement Plan Needs Assessment-Zone 1 Voltage Support requirements to 2010”, July 2005. This is the same as assumed by the Electricity Commission for the assessment of the transmission alternatives: “ Transmission Augmentations into Auckland :Technical analysis of Transpower’s Proposal and Short short-listed Alternatives”, Part I”, April 2006

4 Assumptions and Methodology

The following lists the assumptions and methodology adopted for this analysis:

4.1 General Assumptions

- a). Upgrades of the existing transmission assets (e.g: thermal upgrade and re-conductoring) will progress as planned.
- b). 1 X 33 Mvar + 2 X 50 Mvar synchronous condensers are assumed to be available at Otahuhu in addition to the presently available 2x33 Mvar condensers at Otahuhu.
- c). The Arapuni-Pakuranga 110 kV line is assumed to be decommissioned 18 months prior to the commissioning of a new transmission line between Whakamaru and Otahuhu as the new line utilises some of the route along the Arapuni-Pakuranga line;
- d). The new Generator at Southdown (50 MW) is not assumed in the studies. However, the impact of the unit is considered appropriately in the development plans by adjusting the transfer limit.

4.2 Security Criteria

The transmission plans are developed in accordance with the Grid Reliability Standards (GRS). Transpower's interpretation of the GRS is that it is considered reasonable and prudent to assume the largest single shaft generator in the region (Otahuhu CCGT) may not be available to provide support during a contingency.

The assumption is justified by:

- The size of the Otahuhu CCGT unit, which has a significant impact on supply security and can significantly influence the Power Transfer Capability to the UNI;
- Generators having a lower level of availability compared to transmission lines, particularly thermal generation plant. There have been instances in the past when the Otahuhu CCGT has been out of service for prolonged periods.

4.2.1 Contingencies considered

In addition to an outage of the Otahuhu CCGT, the following contingencies were considered to determine the development plans for all the options:

- a). Loss of any single transmission circuit connecting the UNI from the south¹⁴;
- b). Loss of a cable from Ormiston Road/south of Auckland to Otahuhu or Pakuranga and up to Penrose;
- c). Loss of a single generating unit in the UNI or Huntly;
- d). Loss of a 400/220 kV and 220/110 kV interconnecting transformer;
- e). Loss of a significant reactive source in the UNI.

¹⁴ The loss of other transmission circuits was not considered to be within the scope of this analysis because the other circuits are not expected to have a material impact on the requirement for transmission augmentations into Auckland.

4.2.2 Steady State Planning Criteria

The planning criteria used in the studies is as follows:

- a) Transmission lines are limited to 100% of their respective winter and summer rating with no short term overload capability.
- b) Cables are limited to 114% of their rating to accommodate their short term overload capability;
- c) Existing transformers are limited to 120% of their continuous rating, assuming that the transformers are cyclically loaded;
- d) The 400/220 kV interconnecting transformers are limited to 116.67% of their continuous rating, assuming that the transformers are cyclically loaded;
- e) Voltage stability of the power system maintained with an additional 5% of demand above the forecast level to account for modelling inaccuracies.

4.2.3 Dynamic Analysis

The proposed development plans provide adequate transmission capacity into the UNI and maintain steady state voltages within the Electricity Governance Rule limits following a contingency. The plans were developed using steady state analysis (power flow and voltage stability) of the power system.

Transient performance of the connected generators and the loads (especially the motor loads) could affect the stability of the power system following a transmission disturbance and will require more detailed power system simulation.

Past studies indicate that additional investment in the form of dynamic reactive power support (e.g. synchronous condensers or SVCs) is required to ensure power system stability. As the extra dynamic reactive support is mainly dependent on the characteristics of the connected rotating plant, it is assumed that additional reactive power requirements will approximately be the same for all the transmission alternatives. As such, it has not been included within the development plans outlined in this report.

4.3 Planning Horizon

The analysis was originally based on Transpower's high demand forecast and subsequently adjusted to match the EC prudent peak demand forecast and spans a period of 32 years to 2042. The studies were carried out for the following years:

- a). Every second year from 2010 to 2022
- b). Every five years from 2025 to 2040
- c). 2042

For the purpose of determining the accurate timing of the critical investments, the development plans at the intermediate years were also considered where necessary.

4.4 Methodology for the analysis

This analysis is mainly based on load flow calculations. All the plans developed have taken into account the requirement for winter and summer demand/generation scenarios.

4.4.1 Transmission Plan

Transmission development plans ensure that the system remains stable and the transmission assets remain within their rated capacity for all credible contingencies. Appropriate seasonal variations in the demand, circuit ratings and generation dispatch constraints were assumed in determining the loading of the transmission circuits.

The transmission development plans were initially developed using the 2005 Transpower high demand forecast. The plans were later adjusted to match the EC prudent demand forecast by aligning the years for a given level of demand. The higher EC prudent demand forecast generally resulted in advancing the planned developments by approximately one year.

4.4.2 Transfer Limit

The transfer limit into the UNI is defined as the maximum UNI demand that can be supplied through the transmission system while ensuring that the power system would remain in a satisfactory state following any single credible contingency event occurring on the core grid, whether OTC is in or out of service.

Huntly generation has a pronounced influence on the transfer limit. Figure 4-1 represents the reduced network between Otahuhu, Huntly and Whakamaru. High Huntly generation increases the loading on the 220 kV circuits between Huntly and Otahuhu. By contrast, low Huntly generation requires more generation from Whakamaru and South of Whakamaru. This increases the loading on the 220 kV circuits from Whakamaru to Huntly and from Whakamaru to Otahuhu.

In calculating the transfer limit an approximate optimum mix of Huntly generation and generation from Whakamaru and south is dispatched so that the power transmission to the UNI is maximised under all critical contingencies.

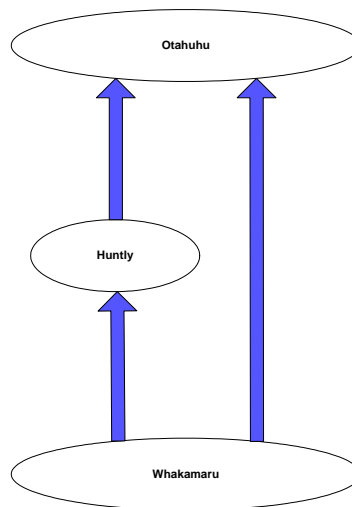

Figure 4-1 Reduced network between Otahuhu, Huntly and Whakamaru

A sample of the calculation methodology for transfer limits is shown in Figure 4-2

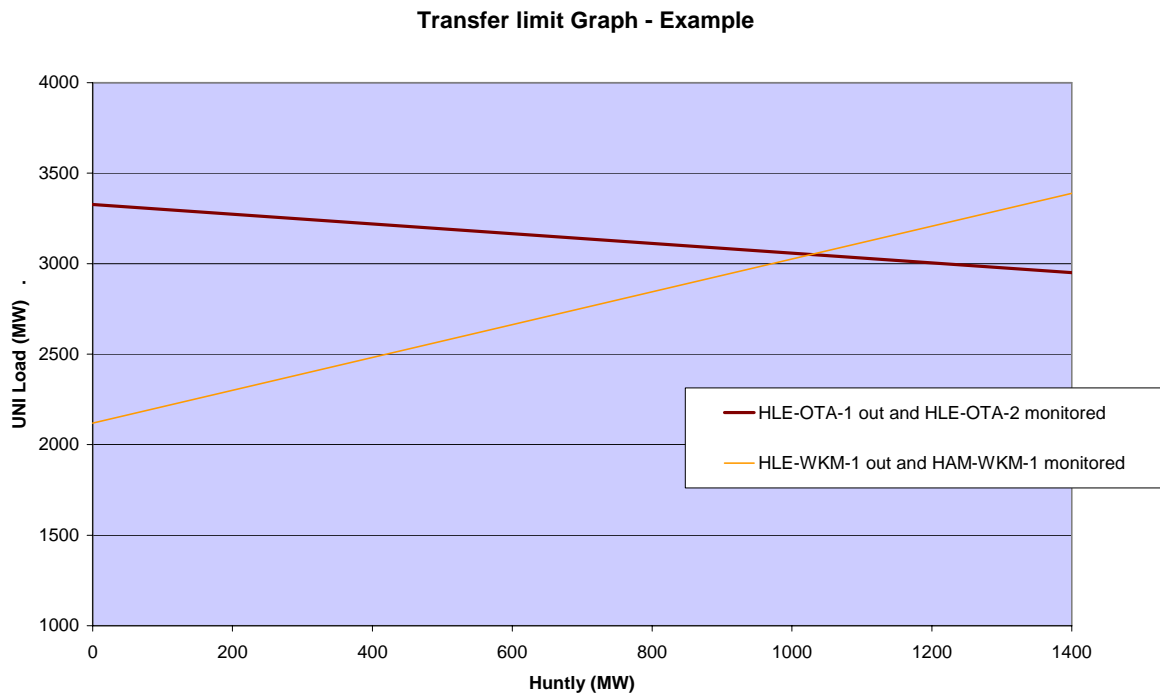

Figure 4-2 Sample Transfer Limit Graph

The figure shows the two lines, HLE-OTA-2 and HAM-WKM-1, which are most critically loaded (under contingency). In the actual calculation, there are a number of such curves to represent all the contingencies being considered. It represents 100% loading of the monitored lines, for a particular UNI demand and Huntly despatch. The intersection of the lowest two lines provides the maximum UNI transfer possible and the corresponding Huntly Generator despatch required.

The transfer limits represent the maximum available transfer capacity between Whakamaru and Otahuhu. However, the maximum demand that can be supplied within the UNI could be constrained within the region and needs to be relieved irrespective of the transmission developments supplying the UNI from south.

4.4.3 Reactive Power Support

Adequate reactive power support developments were planned to ensure voltage stability of the power system. This includes allowing for a stability margin equivalent to 5% of the forecast demand (refer section 3.3). In planning the reactive power support requirements, outages of major generating and reactive plant in the UNI were considered in addition to the critical transmission outages. Adequate reactive power support ensures that:

- voltage stability of the power system is maintained (including a 5% stability margin)
- acceptable voltages (0.90 pu – 1.1 pu) are maintained at all the transmission busses
- sufficient reactive reserves are maintained, pre-contingency, in the dynamic reactive devices (generators, synchronous condensers and SVCs) so that post-contingency switching of the capacitors is not required.

This analysis has not attempted to optimise the location or the quantity of reactive power support. For the purpose of comparing the transmission options, all the reactive support is

assumed to be located at Otahuhu or Huntly, though in reality some of this will be spread across other substations in the UNI. In the case of dynamic reactive sources, Otahuhu/Pakuranga (depending on the option) may be the preferred location, as the dynamic reactive plant is primarily to address a transmission contingency in the corridor.

5 Overview of the Transmission Options

This report describes a number of alternative options for transferring power between Whakamaru and the UNI. The options assessed encompass a large number of 220 kV and 400 kV transmission solutions for ensuring supply reliability to the UNI region as well as providing adequate diversity of the supply to the region. Four options assessed in detail are:

Option 1: 220 kV into Pakuranga and Otahuhu. This option involves:

- Building a new 220 kV double circuit transmission line between Whakamaru and Ormiston Road and 220 kV underground cables from Ormiston Road initially to Pakuranga and later to Otahuhu ;
- Installing series compensation on the transmission line, when required, to increase the transfer capacity to UNI;
- Building an additional 220 kV double circuit transmission line from Whakamaru to the UNI when the transfer capacity to the UNI is exhausted. This transmission line will be built from Whakamaru to an intermediate point south of Auckland (e.g. Flatbush) and a 220 kV cable will be installed from this point to a substation in Auckland¹⁵. This line will be series compensated, when required.

Option 2: 400 kV into Ormiston Road, 220 kV into Pakuranga and Otahuhu. This option involves:

- Building a new 400 kV double circuit transmission line between Whakamaru and Ormiston Road and 220 kV underground cables from Ormiston Road initially to Pakuranga and later to Otahuhu;
- The transmission line will initially be operated at 220 kV;
- Installing series compensation on the new transmission line to increase the transfer capacity to UNI first;
- Converting the transmission circuits to 400 kV operation when the capacity of the series compensated circuits reach their capacity limits under 220 kV operation.

Option 3: 220 kV incremental development plan. This option involves:

- Duplexing the Otahuhu – Whakamaru A & B single circuit transmission lines;
- Re-terminating the Otahuhu-Whakamaru A and B transmission lines at a point south of Auckland and 220 kV cables from this point to Pakuranga¹⁶;
- Bussing the Otahuhu-Whakamaru A and B transmission lines at Huntly East;
- When required, build a new 220 kV double circuit transmission line between Whakamaru and Ormiston Road and 220 kV underground cables from Ormiston Road initially to Pakuranga and later to Otahuhu ;
- Installing series compensation on the transmission line, when required, to increase the transfer capacity to UNI;
- Building an additional 220 kV double circuit transmission line from Whakamaru to UNI when the transfer capacity to the UNI is exhausted. It is likely that the transmission line will be built from Whakamaru to an intermediate point south of Auckland (e.g. Flatbush) and a 220 kV cable will be installed from this point to a substation in Auckland.

¹⁵ For the purposes of this study, this has assumed to be at Otahuhu but it may be some other more appropriate substation in Auckland.

¹⁶ The line section from Otahuhu to Ormiston Road will **not** be duplexed and will be disconnected.

Option 4: Replacing Existing 220 kV conductors with High Temperature Conductors. This option involves:

- Replacing the existing conductors on Otahuhu-Whakamaru A & B lines with duplex High Temperature Conductors and terminating them at a point south of Auckland with 220 kV cables from there to Pakuranga;
- Installing series compensation the lines and bus them at Huntly East when required
- Replacing the existing conductors on Otahuhu-Whakamaru C line with duplex High Temperature Conductors and series compensation when required;
- Building a new 220 kV double circuit transmission line from Whakamaru to Ormiston Road with 220 kV cable from there to Pakuranga and later to Otahuhu;
- Installing series compensation the new line, when required.

The remaining options that were studied are described in Appendix F

5.1 Common Augmentations

A number of augmentations common to all the development options have been drawn from the Annual Planning Report 2006 (Sections 5 to 13). Table 5-1 lists the common network augmentations described in the Annual Planning Report and assumed in the present analysis.

Year	Common Network Augmentations	Status with Electricity Commission / Project Status
By 2010	Thermal upgrade of 220 kV HLY-OTA-1 circuit (HLY-OTA section of OTA -WKM C double circuit line) from 493/404 MVA to 670/614 MVA.	Submitted to Electricity Commission for Approval Completed
	Thermal upgrade of 220 kV WRK-PPI-WKM-1 circuit (WRK- WKM B single circuit line) from 292/239 MVA to 448/421 MVA	Submitted to Electricity Commission for Approval Completed
	Shift half of HAM 33 kV load to new substation at TWH on HLY-TMN 220 kV circuit.	Customer Specific
	Thermal upgrade of 220 kV BPE-HAY-1 circuit (BPE-HAY A single circuit line) from 247/202MVA to 335/307 MVA	Submitted to Electricity Commission for Approval Completed
	Thermal upgrade of 220 kV BPE-HAY-2 circuit (BPE-HAY B single circuit line) from 247/202MVA to 335/307 MVA	Submitted to Electricity Commission for Approval Completed
	Thermal upgrade of 220 kV TKU-WKM-1 circuit (TKU-WKM section of single circuit BPE- WKM A line) from 281/244 MVA to 335/307 MVA	Submitted to Electricity Commission for Approval Project complete
	Thermal upgrade of 220 kV TKU-WKM-2 circuit (TKU-WKM section of single circuit BPE- WKM B line) from 281/244 MVA to 335/307 MVA	Submitted to Electricity Commission for Approval Project complete
	Thermal upgrade of 220 kV RPO- WRK-1 circuit (RPO- WRK section of BPE-WRK A single circuit line) from 292/239 MVA to 370/333 MVA	Submitted to Electricity Commission for Approval Project in progress

NORTH ISLAND GRID UPGRADE PROJECT – AMENDED PROPOSAL
ATTACHMENT D – TECHNICAL ASSESSMENT OF MODIFIED OPTIONS

Year	Common Network Augmentations	Status with Electricity Commission / Project Status
	Thermal upgrade of 220 kV BPE-TKU-1 circuit (BPE-TKU section of BPE- WKM A single circuit line) from 246/202 MVA to 335/307 MVA	Submitted to Electricity Commission for Approval Project in progress
	Thermal upgrade of 220 kV BPE-TKU-2 circuit (BPE-TKU section of BPE- WKM B single circuit line) from 246/202 MVA to 335/307 MVA	Submitted to Electricity Commission for Approval Project in progress
	Thermal upgrade of 220 kV OTA-WKM-1 circuit (OTA-WKM A single circuit line) from 246/202 MVA to 323/293 MVA	Electricity Commission Approved
	Thermal upgrade of 220 kV OTA-WKM-2 circuit (OTA-WKM B single circuit line) from 246/202 MVA to 323/293 MVA	Electricity Commission Approved
	Bus the 220 kV HAM-HLY-1, HLY-OTA-1 and OTA-WKM-3 circuits (OTA -WKM C double circuit line) at HLE in a breaker-and-a-half configuration	Electricity Commission Approved
	Thermal upgrade of 220 kV HEN-OTA-1, HEN-SWN-1 and OTA-SWN-1 circuits (HEN-OTA double circuit line) to 938/980 MVA.	Electricity Commission Approved Completed
	Thermal upgrade of 220 kV OTA-PEN 5 and 6 circuits (OTA-PEN C double circuit line) to 469/492 MVA.	Electricity Commission Approved
	Install second Wilton 100 MVA, 220/110 kV Interconnecting transformer	To be submitted for approval
	Build a new 110kV Switching Station at Hairini to create a shared 110kV circuit (HHI-PIE-TGA-MTM circuit).	Electricity Commission Approved
	Shift 40% of Load from HIN to ARI (to compensate for new GXP at Putaruru).	Customer Specific
	Install new +/- 100 Mvar SVC at ALB	Electricity Commission Approved
	Install new 100 Mvar Capacitors at ALB	Electricity Commission Approved
	Install new 24 Mvar Capacitors at KTA	Electricity Commission Approved
	Install new 25 Mvar Capacitors at TGA	Electricity Commission Approved
2011	Reconductor the 220 kV BPE-TKU-1 circuit (BPE-TKU section of BPE- WKM A single circuit line)	To be submitted for approval
	Reconductor the 220 kV BPE-TKU-2 circuit (BPE-TKU section of BPE- WKM B single circuit line)	To be submitted for approval
	Reconductor the 220 kV TKU-WKM-1 circuit (TKU-WKM section of single circuit BPE- WKM A line)	To be submitted for approval

Year	Common Network Augmentations	Status with Electricity Commission / Project Status
	Reconductor the 220 kV TKU-WKM-2 circuit (TKU-WKM section of single circuit BPE- WKM B line)	To be submitted for approval
	Thermal upgrade of 220 kV BPE-TNG-1 and RPO-TNG-1 circuits (BPE-TNG-RPO section of the BPE-WRK A single circuit line)	To be submitted for approval
	Reconductor the 220 kV OHK-WRK-1, ATI-OHK-1 and ATI-WKM-1 circuits (WRK-WKM A single circuit line)	To be submitted for approval
	Replace OTA interconnecting transformers (T2 and T4) with two new 250 MVA transformers	To be submitted for approval
	Replace HEN interconnecting transformers (T1 and T5) with two new 250 MVA transformers.	To be submitted for approval
	Install two new 220/110kV interconnecting transformers at HHI and operate the HHI-TGA-1 circuit at 220kV.	To be submitted for approval
2013	Build a new 220 kV GXP at Hobson Street (HOB)	To be submitted for approval
	Build a new 220 kV GXP at Wairau Road (WRU)	To be submitted for approval
	Place the first new PEN-HOB 220 kV cable in service	To be submitted for approval
	Place the first new HOB-WRU 220 kV circuit in service	To be submitted for approval
	Place the first new 220 kV WRU- ALB circuit in service	To be submitted for approval
	Install a new 12 Ohm Series reactor ¹ out of Penrose (to reduce the cable impedance for better power sharing)	To be submitted for approval
	Install a new 250 MVA, 220/33 kV, 10% supply transformer at WRU	To be submitted for approval
	Install a new 250 MVA, 220/110 kV, interconnecting transformer at HOB	To be submitted for approval
	Shift 50% Of PEN 110 kV load (PEN_Quay2) to HOB	To be submitted for approval
2014	Build a third 110kV HAM-WHU Circuit	To be submitted for approval
2015	Bus the 220 kV HLY-SFD-1 circuit at TMN	To be submitted for approval
	Add BOB Tee (59% from HLY) to 220 kV GLN-HLY circuit and feed BOB via a new 200 MVA, 220/110 kV interconnecting transformer ²	To be submitted for approval

Year	Common Network Augmentations	Status with Electricity Commission / Project Status
2017	Build a new ROS 220 kV substation	To be submitted for approval
	Install a new ROS-PEN 220 kV cable	To be submitted for approval
	Install a new 250 MVA, 220/110 kV interconnecting transformer at ROS	To be submitted for approval
2019	Install a third 200 MVA, 220/110 kV interconnecting transformer ,at TRK	To be submitted for approval
2020	Place the second 220 kV PEN-HOB-WRU-ALB cable in service	To be submitted for approval
2021	Reconductor the WRK-PPI-WKM-1 circuit (WRK-WKM B single circuit line)	To be submitted for approval
Notes: 1. This value is assumed based on some preliminary analysis, but this is subject to change 2. This is different for Option 3 3. The augmentations shown above are based on Transpower’s 2005 medium demand forecast. As per the EC prudent demand forecast these developments may need advancing.		

Table 5-1: Common Augmentations for All Options

In this report, the reactive power requirements at Otahuhu and Huntly are explicitly described with each transmission development plan. However, additional reactive power support required for maintaining the desired level of voltages at the rest of power system nodes is common for all the options considered. The development plan for the common reactive support requirements is shown in Table 5-2

Year	Location	Quantity (Mvar)	Static(S) / Dynamic (D)
2012	KTA	12	S
2014	MDN	60	S
2018	KTA	12	S
2022	MDN	60	S
2025	WKO	30	S
2027	KTA	12	S
2031	MPE	24	S
2033	MPE	24	S
2033	WKO	30	S
2035	MPE	24	S
2038	MPE	24	S
2039	HAM	50	S

2039	HAIRINI	100	S
2042	KTA	12	S
	Total	474	

Table 5-3: Common Reactive Support

The relevant network augmentations that impact on the level of power transfer into the UNI are shown in Figure 5-1

6 Analysis of the results

In planning the transmission augmentations, investments are deferred as long as possible in order to obtain the maximum economic benefit. The projects need to be commissioned before the peak period (winter and summer, as the case may be) of the year when the transmission capacity may become inadequate. Hence the Developments are planned for the year before the transmission constraint appears.

6.1 Summary of the analysis

The transfer limits for the transmission options are shown in Figure 6-1 along with the prudent demand forecasts.

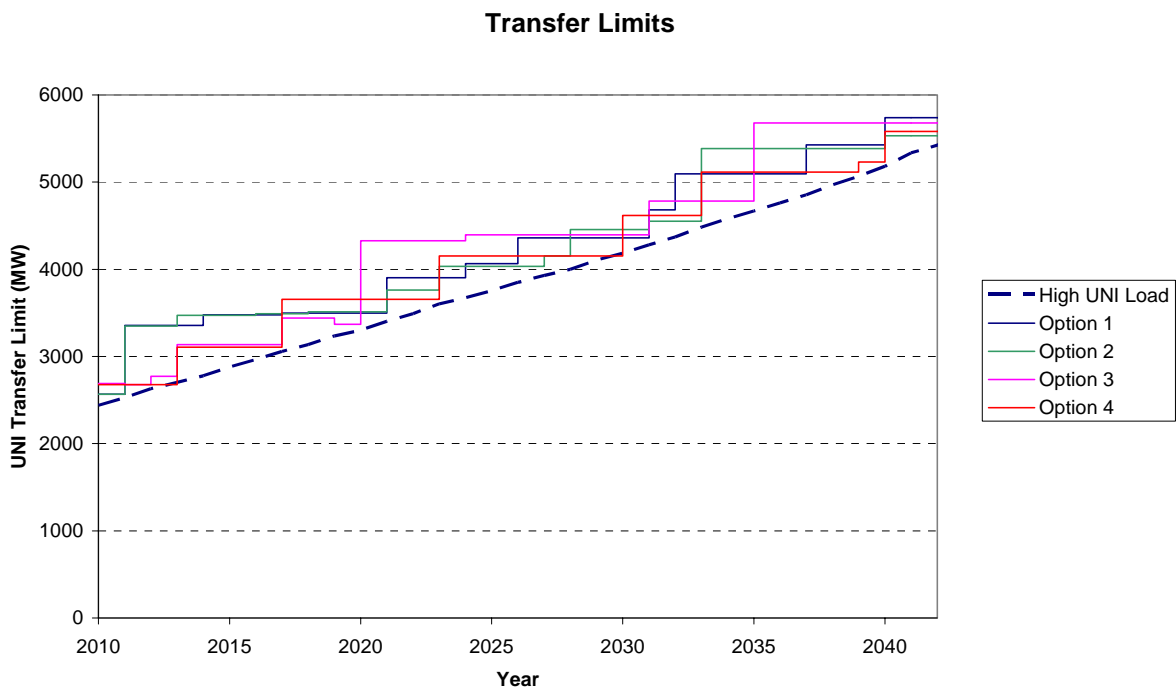

Figure 6-1: Transfer Limits for the transmission options

While the 400 kV transmission line between Whakamaru & Ormiston Road provides an ultimate transmission capacity over 5,500 MW to the UNI, a series of intermediate transmission investments are also required to remove other system limitations to achieve this capacity over the planning horizon.

By contrast, the first 220 kV transmission line between Whakamaru and Ormiston Road will provide an ultimate incremental capacity of approximately 4,400 MW. This option will require a second 220 kV transmission line from 2031 to further augment the supply capacity to the UNI. As with the 400 kV transmission option, a series of intermediate transmission investments is required to remove other system limitations and achieve the full capacity of the 220 kV lines over the planning horizon.

The option involving duplexing of A&B circuits provides a capacity of 3400 MW, when a new 220 kV double circuit line is required. This new line increases the capacity to 4400 MW,

when a second double circuit line is required. With another double circuit line in 2035, the capacity increases to 5700 MW. As with the 400 kV transmission option, a series of intermediate transmission investments is required to remove other system limitations and achieve the full capacity of the 220 kV lines over the planning horizon.

The option involving replacing existing conductors on Otahuhu-Whakamaru A, B and C lines with HTC provides capacity increases in a staged manner. Replacing Otahuhu-Whakamaru A&B lines with HTC and series compensation increases the capacity to 3655 MW. The Otahuhu-Whakamaru C line is re-conducted with HTC and series compensated, which increases the transfer limit to approximately 4154 MW. A new 220 kV double circuit line is built in 2029. This along with other augmentations, increases the transfer limit to approximately 5232 MW. Installing series compensation on the new 220 kV transmission line in 2040 increases the transfer limits to approximately 5581 MW.

6.2 Option 1: 220 kV into Pakuranga and Otahuhu

This option involves building new 220 kV transmission lines from Whakamaru to the Upper North Island that are then series compensation to increase their capacity when required. The existing network is not augmented except as identified in Section 5.1.

The analysis assumes the new 220 KV transmission lines are constructed with high capacity conductors (twin Chukar) to facilitate comparison with the 400 kV development options.

The first 220 kV transmission line is built by 2011 increasing the transfer limit into the UNI to approximately 3,350 MW.

In 2021, series compensation is installed on the new transmission line. This, along with other augmentations, increases the transfer limit to the UNI to approximately 3,900 MW.

By 2026, the 220 kV OTA-WKM 1 & 2 circuits are anticipated to constrain power transfer to the UNI. Installing series reactors on these circuits will remove the constraint by increasing the transfer limit to the UNI to approximately 4,400 MW. This provides sufficient capability till 2031.

In 2031, a second 220 kV double circuit transmission line is built, which together with other augmentations will increase the transfer limit to the UNI to approximately 5,400 MW¹⁷.

In 2040, series compensation is installed on the second 220 kV double circuit transmission line to increase the transfer limit to the UNI to approximately 5750 MW.

The Thermal and the Reactive development plans for Option 1 are shown in Table 6-1 and Table 6-2 and pictorially in Figure 6-2.

Option 1: 220kV to Pakuranga				
Transfer Limit (MW)	Year	Augmentation	Type of Project	Reason
2571	2010	Decommission 110 kV ARI-PAK line	GIT	New 220 kV transmission line uses this line route
3358	2011	Build new 220kV double circuit line (2 x Chukar 75°C) from WKM to ORM	GIT	To prevent overloading of 220 kV HLE-OTA-1 circuit for a HLE-OTA-2 circuit contingency; To prevent overloading of HLE-WKM on a HAM-WKM circuit outage; OTA-WKM 1 & 2 circuits overloads when the Huntly generation is re-dispatched to reduce overloads on HLE-OTA circuits, for a contingency of HAM-WKM circuit
		Install two new 220 kV cables from ORM-PAK	GIT	
		Build a new 220kV substation at PAK	GIT	
		Install three 120 MVA, 220/33 kV supply transformers at PAK	GIT	

¹⁷ For the purposes of modelling, it has been assumed that second 220 kV line will terminate at ORM. However, it is more likely that the second line will have a different route and the transition station will be at another location to provide diversity into the UNI.

Option 1: 220kV to Pakuranga				
Transfer Limit (MW)	Year	Augmentation	Type of Project	Reason
		Increase operating voltage of the OTA-PAK 1 and 2 circuits (OTA-PAK A transmission line) to 220 kV	GIT	
		Install 1 st 220 kV PAK-PEN Cable	GIT	To provide diversity of supply to the UNI and to prevent the 220 kV OTA-PEN-6 circuit from overloading for contingency on the OTA-PEN-5 circuit
3478	2013	Re-conductor 110 kV ARI-HAM 1 & 2 circuits (ARI-HAM B double circuit line) with Nitrogen conductors at 75°C.	Common	Prevent 110kV ARI-HAM-2 circuit from overloading when parallel ARI-HAM-1 circuit is out of service (during Summer peak demand).
3498	2017	Install 2 nd 220 kV PAK-PEN Cable	GIT	To prevent the 220 kV OTA-PEN 5 and 6 circuits from overloading when the 220 kV PAK-PEN-1 cable is out of service.
		Install 1 st 220 kV OTA-PEN Cable	Modelled	To prevent the 220 kV PAK-PEN cable 2 from overloading during a contingency of the parallel PAK-PEN cable
		Install 110 kV OTA-WIR cable	Common	To prevent overloading of the parallel 110 kV WIR-OTA circuit for a contingency of the parallel BOB-WIR-OTA circuit
3904	2021	Install 50% series compensation on the new 220 kV ORM-WKM 1 & 2 circuits	Modelled	To prevent overloading of HLE-WKM on a HAM-WKM circuit outage; 220 kV HLE-OTA-1 is close to its capacity for a HLE-OTA-2 circuit contingency; OTA-WKM 1 & 2 circuits are close to capacity for the ORM-WKM contingency
		Build new switching station at ORM	Modelled	
		Install 1 st 220 kV ORM-OTA Cable	Modelled	
		Install 2 nd 220 kV ORM-OTA Cable	Modelled	To prevent overloading of the ORM-PAK 2 cable for a contingency on the ORM-PAK-1 cable
4065	2024	Install 2 nd ROS 220/110 kV Interconnecting transformer .	Common	To prevent overloading of the ROS interconnecting transformer for a contingency of OTA interconnecting transformer T5

Option 1: 220kV to Pakuranga				
Transfer Limit (MW)	Year	Augmentation	Type of Project	Reason
4362	2026	Install 15 ohms Series Reactors on the 220 kV OTA-WKM 1 and 2 circuits	Modelled	To prevent overloading on OTA-WKM 1 & 2 circuits for a contingency of ORM-WKM-1 circuit
		Thermally upgrade the 220 kV HAM-HLY-1, HLE-WKM and HAM-WKM-1 circuits (HLE-HAM-WKM section of the OTA-WKM C double circuit line) to 2xGoat 80°C	Modelled	To prevent overloading on 220 kV HAM-WKM circuit when the 220 kV ORM-WKM-1 circuit is out of service.
		Re-conductor 110 kV HAM-BOB 1 and 2 circuits with Nitrogen Conductors.	Common	To prevent overloading of HAM-BOB 1 circuit for a contingency of the parallel circuit (during Summer Peak period).
	2027	Install 2 nd PEN-ROS Cable	Common	To prevent overloading of the OTA interconnecting transformer T5 when the 220 kV PEN-ROS Cable is out of service.
4682	2031	Build 2 nd 220kV Double Circuit line between WKM and south of Auckland ¹	Modelled	To prevent overloading on one of the 220 kV ORM-WKM1 circuit on the contingency of the parallel circuit. The OTA-WKM A&B circuits also overload for the same contingency
		Install 1 st 220kV Cable between south of Auckland line termination and PAK.	Modelled	To prevent overloading on one of the 220 kV ORM-PAK cable for a contingency of the parallel cable.
5096	2032	Install 2 nd 220 kV OTA-PEN cable	Modelled	To prevent overloading of one of the 220 kV PAK-PEN cable when the parallel cable is out of service
		Install 3 rd ROS 220/110 kV interconnecting transformer	Common	To prevent overloading of the remaining ROS interconnecting transformer for a contingency on one of the ROS interconnecting transformers.
	2036	Install a 75 MVA Phase Shifting Transformer on the 110 kV ARI-BOB-1 Circuit	Modelled	To limit the overloads on the ARI-BOB circuit for a contingency of HLY-BOB-GLN 220 kV circuit (which also takes out BOB inter connector)

Option 1: 220kV to Pakuranga				
Transfer Limit (MW)	Year	Augmentation	Type of Project	Reason
5429	2037	Install a new 220/110 kV Interconnecting transformer at OTA (similar to T5)	Common	To prevent overloading on OTA T5 for a contingency on OTA T3.
		Install 1 st 220 kV south of Auckland line termination - OTA Cable	Modelled	To prevent overloading the 220 kV ORM-PAK and ORM-OTA Cables for a contingency on one parallel cables
5740	2040	Install 50% Series Compensation on the 220 kV WKM-ORM 3 & 4 circuits (new line)	Modelled	To prevent overloading on the 220 kV OTA-WKM 1 & 2 circuits and PAK-WKM-2 circuits for a contingency of PAK-WKM-1 circuit is out of service
<p>Notes:</p> <ol style="list-style-type: none"> For the purposes of modelling, it has been assumed that second 220 kV line will terminate at ORM. However, it is more likely that the second line will have a different route and the transition station will be at another location to provide diversity into the UNI. The capacity of the 220 kV cables from ORM to OTA/PAK match the capacity of the transmission lines. There is no benefit for installing forced cooling on the cables in this option as it does not provide any additional capacity into the UNI. 				

Table 6-1: Thermal Development Plan for Option 1

Year	Location	Quantity (Mvar)	Static/Dynamic*
2008	OTA	250	S
2009	OTA	100	S
2015	OTA	100	S
2017	OTA	100	D
2019	HLY	100	S
2022	OTA	200	S
2026	HLY	100	S
2027	OTA	100	D
2029	HLY	100	S
2029	OTA	250	S
2035	OTA	250	S
2038	OTA	150	S
2042	OTA	400	S
Total		2200	

Table 6-2: Reactive Plan for Option 1 (220 kV to Pakuranga)

The transfer limit for this option is shown in **Figure 6-3**.



Figure 6-3 Transfer Limits against forecast demand for Option 1

6.3 Option 2: 400 kV into Ormiston Road and 220 kV cables to Pakuranga and Otahuhu (late conversion to 400 kV)

This option involves building a new 400 kV transmission line from Whakamaru to the Upper North Island that will initially be operated at 220 kV and series compensated to maximise the power transfer capability into the UNI prior to converting to 400 kV operation. The existing network is not augmented except as identified in Section 5.1.

The 400 kV transmission line will be built by 2011 and initially operated at 220 kV. This increases the transfer limit to the UNI to approximately 3,400 MW.

In 2021, series compensation is installed on the new transmission line. This, along with other augmentations, increases the transfer limit to the UNI to approximately 4,500MW.

In 2033, the new transmission line is upgraded to 400 kV operation by commissioning new 400 kV sub-stations at Whakamaru and Ormiston Road.. Along with other developments, this increases the transfer limit to the UNI to approximately 5,500 MW.

The Thermal and the Reactive development plans for Option 2 are shown in Table 6-3 and Table 6-4 and is shown pictorially in Figure 6-4.

Option 2 : 400 kV to Ormiston Road (deferred conversion to 400 kV)				
Transfer Limit (MW)	Year	Augmentation	Type of Project	Reason
2567	2010	Decommission the 110 kV ARI-PAK line	GIT	New 400 kV transmission line uses this line route
3349	2011	Build new 400 kV double circuit line (Triplex AAAC Sulphur conductor) from WKM to ORM, operated at 220 kV	GIT	To prevent overloading of 220 kV HLE-OTA-1 circuit for a HLE-OTA-2 circuit contingency;
		Install two new 220 kV cables from ORM-PAK	GIT	To prevent overloading of HLE-WKM on a HAM-WKM circuit outage; OTA-WKM 1 & 2 circuits overloads when the Huntly generation is re-dispatched to reduce overloads on HLE-OTA circuits, for a contingency of HAM-WKM circuit
		Build a new cable transition station at ORM	GIT	
		Build a new 220 kV substation at PAK	GIT	
		Increase operating voltage of the OTA-PAK 1 & 2 circuits (OTA-PAK A transmission line) to 220 kV	GIT	
		Install three 120 MVA, 220/33 kV supply transformers at PAK	GIT	
		Install 1 st 220 kV PAK-PEN Cable	GIT	To provide diversity of supply to the UNI and to prevent the 220 kV OTA-PEN-6 circuit from overloading for contingency on the OTA-PEN-5 circuit

Option 2 : 400 kV to Ormiston Road (deferred conversion to 400 kV)				
Transfer Limit (MW)	Year	Augmentation	Type of Project	Reason
3472	2013	Re-conductor 110 kV ARI-HAM 1 & 2 circuits (ARI-HAM B double circuit line) with Nitrogen 75°C conductors.	Common	Prevent 110kV ARI-HAM-2 circuit from overloading when parallel ARI-HAM-1 circuit is out of service (during Summer peak demand).
	2017	Install 2 nd PAK-PEN cable	GIT	To prevent the 220 kV OTA-PEN 5 & 6 circuits from overloading when the 220 kV PAK-PEN cable is out of service
3762	2021	Install 55% compensation on WKM-ORM 1 and 2 circuits	Modelled	To prevent overloading on 220 kV HAM-WKM circuit when the 220 kV HLE-WKM-1 circuit is out of service
		Install 110 kV OTA-WIR cable	Common	To prevent overloading of the parallel 110 kV OTA-WIR for a contingency of the parallel BOB-WIR-OTA circuit
		Install 1 st 220 kV PEN-OTA cable	Modelled	To prevent the 220 kV PAK-PEN cable from overloading during a contingency of the parallel PAK-PEN cable
		Build new switching station at ORM	Modelled	
		Install 1 st 220 kV ORM-OTA cable	Modelled	To prevent overloading of the 220 kV ORM-PAK 2 cable when the parallel ORM-PAK 1 cable is out of service
4034	2023	Install 2 nd 220 kV ORM-OTA cable	Modelled	To prevent overloading of the ORM-PAK 2 cable when the parallel ORM-PAK 1 cable is out of service
	2024	Install 2 nd ROS 220/110 kV interconnecting transformer	Common	To prevent overloading of the ROS interconnecting transformer for a contingency of the OTA interconnecting transformer T3
	2026	Re-conductor HAM-BOB 110 kV circuits to Nitrogen Conductors.	Common	To prevent overloading of HAM-BOB 1 circuit for a contingency of the parallel circuit (during Summer Peak period).

Option 2 : 400 kV to Ormiston Road (deferred conversion to 400 kV)				
Transfer Limit (MW)	Year	Augmentation	Type of Project	Reason
4154	2027	Thermally upgrade the 220 kV HAM-HLY-1, HLE-WKM and HAM-WKM-1 circuits (HLE-HAM-WKM section of the OTA-WKM C double circuit line) to 2xGoat 80°C	Modelled	To prevent overloading on 220 kV HAM-WKM circuit when the 400 kV ORM-WKM-1 circuit is out of service.
		Install 2 nd PEN-ROS cable	Common	To prevent overloading of the OTA interconnecting transformer T5 and 110 kV HEP-HEN circuits when the 110 kV PEN-ROS circuit is out of service
4455	2028	Install 20 Ohm reactors on the OTA-WKM 1 & 2 circuits (OTA-WKM A&B lines)	Modelled	To prevent overloading for the 220 kV OTA-WKM 1 and 2 circuits when the 400kV ORM WKM circuit is out of service
4551	2031	Install forced cooling on the 220 kV ORM-PAK cables		To prevent overloading of the remaining 220 KV ORM-PAK cables when one of the ORM-PAK cables is out of service
	2032	Install 3 rd ROS 220/110 kV interconnecting transformer	Common	To prevent overloading of the remaining ROS interconnecting transformer during a contingency on ROS T1.
5384	2033	Install forced cooling on the 220 kV ORM-OTA cables	Modelled	To prevent overloading of the remaining 220 kV ORM-OTA cable when one of the ORM-OTA cables are out of service
		Build new 400 kV substation at Whakamaru	Modelled	To prevent overloading of 220kV ORM-WKM 2 for a contingency on the ORM-WKM 1 circuit
		Build new 400 kV substation at Ormiston Road	Modelled	
		Increase operating voltage of the WKM-ORM circuits to 400 kV	Modelled	
		Install six 400/220 kV, 600 MVA interconnecting transformers at ORM	Modelled	
		Install six 400/220 kV, 600 MVA interconnecting transformers at WKM	Modelled	
		Reduce series compensation on the 400 kV ORM-WKM circuits to 45%	-	

Option 2 : 400 kV to Ormiston Road (deferred conversion to 400 kV)				
Transfer Limit (MW)	Year	Augmentation	Type of Project	Reason
		Install 2 nd PEN-OTA cable	Modelled	To prevent overloading of the PAK-PEN 2 cable when the parallel PAK-PEN 1 is out of service
5533	2037	Install new OTA 220/110 kV interconnecting transformer in parallel with T3 and T5	Common	To prevent overloading of the remaining ROS interconnecting transformers for a contingency on one of the ROS interconnecting transformers
		Install a 75 MVA Phase Shifting Transformer on the 110 kV ARI-BOB circuit	Modelled	To limit the overloads on the ARI-BOB circuit for a contingency of HLY-BOB-GLN 220 kV circuit (which also takes out BOB inter connector)
Notes: 1. The new 400kV transmission line has significantly higher capacity compared to the 220 kV cables from ORM to OTA/PAK. Installing forced cooling on these cables provides increased capacity into the UNI as it allows greater utilisation of capacity of the 400 kV transmission line.				

Table 6-3: Thermal Development Plan for Option 2

Year	Location	Quantity (Mvar)	Static(S) / Dynamic(D)
2008	OTA	250	S
2009	OTA	100	S
2015	OTA	100	S
2017	OTA	100	D
2019	HLY	100	S
2022	OTA	200	S
2023	OTA	100	D
2026	HLY	100	S
2027	OTA	150	S
2029	HLY	100	S
2030	OTA	300	D
2031	OTA	150	S
2040	OTA	300	S
2042	OTA	300	S
Total		2350	

Table 6-4: Reactive Plan for Option 2 (400 kV to Ormiston Road)

NORTH ISLAND GRID UPGRADE PROJECT – AMENDED PROPOSAL
ATTACHMENT D – TECHNICAL ASSESSMENT OF MODIFIED OPTIONS

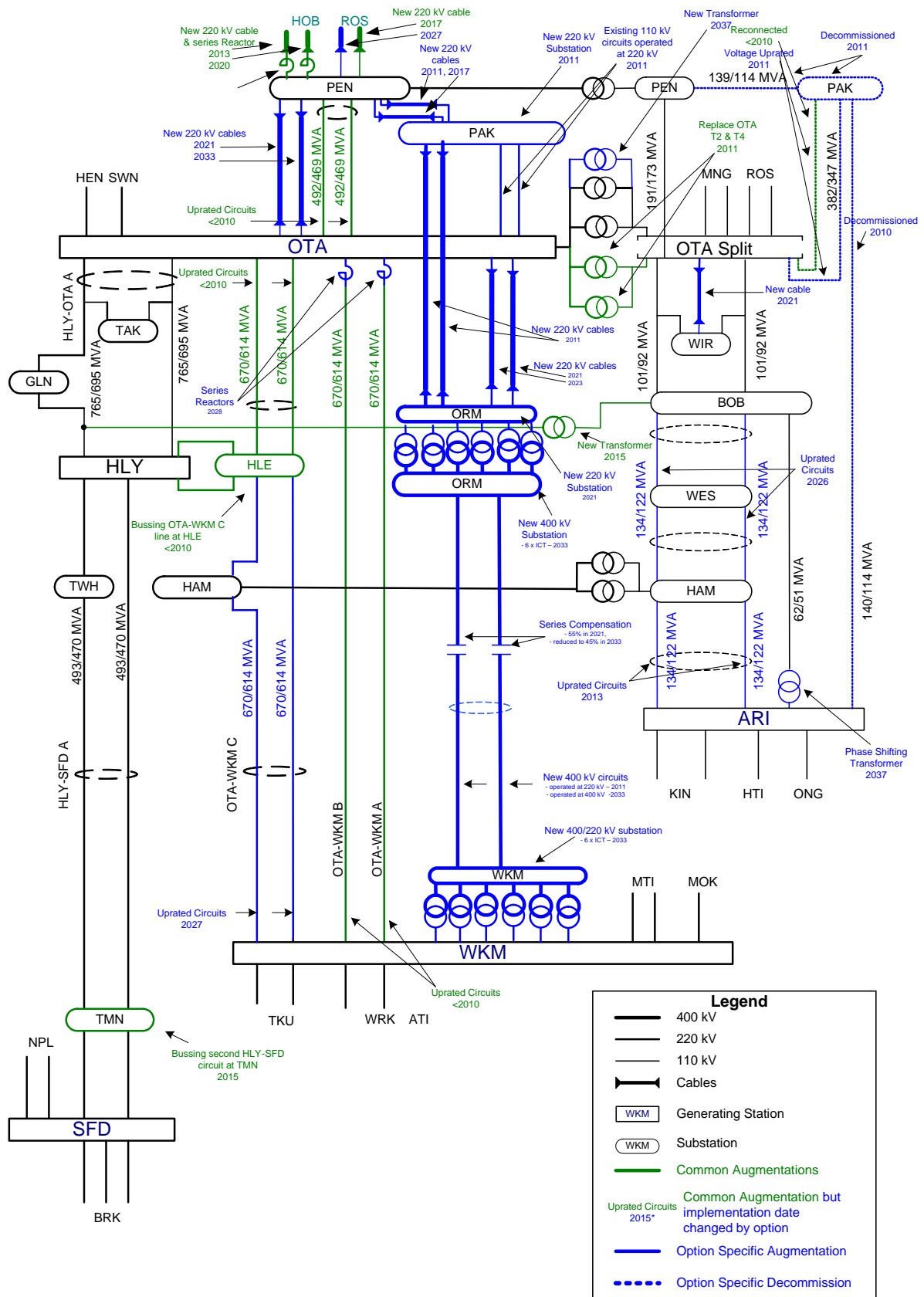

Figure 6-4: Option 2 (400 kV to Ormiston Road)

The transfer limit for this option is shown in Figure 6-5:

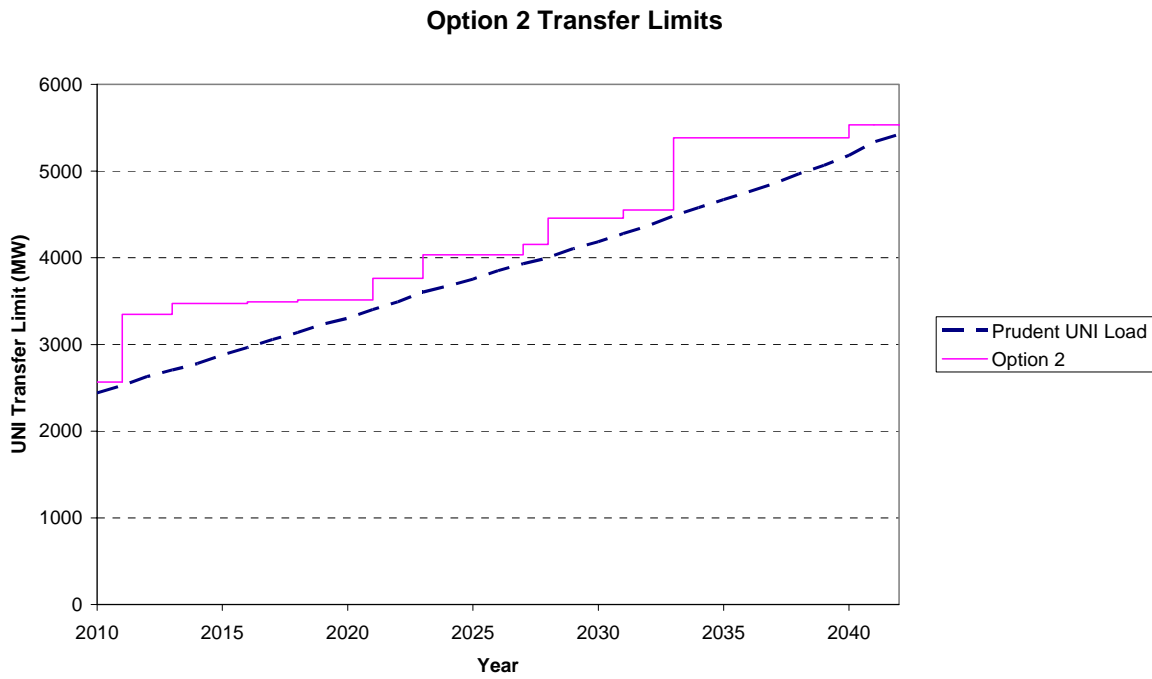

Figure 6-5: Transfer Limits against forecast demand for Option 2

6.4 Option 3: Incremental development plan - Duplexing of Whakamaru-Otahuhu A & B lines

This option includes augmenting the existing network in addition to those identified as in Section 5.1. to defer new investment.

A new 220 kV double circuit transmission line into Pakuranga will be built when transmission capacity into the UNI is exhausted. This option includes installing series capacitors on the new 220 kV lines, when needed to increase the transfer capacity into the UNI. When the new 220 kV transmission line runs out of capacity, a 2nd 220 kV double circuit line is built.

Duplexing the OTA-WKM A&B circuits in 2013 increases the transfer to approximately 3,100 MW.

Other augmentations including bussing the OTA-WKM A&B circuits to Huntly East, increases the transfer capacity to approximately 3,400 MW.

The first new 220 kV double circuit transmission line is built by 2021. This along with other augmentations, increases the transfer limit to approximately 4,400 MW.

Installing 50% series compensation on the new 220 kV transmission line in 2031 increases the transfer limits to approximately 4,800 MW.

In 2035, a second 220 kV double circuit transmission line is built to increase the transfer limit above 5,700 MW.

The Thermal and the Reactive development plans for Option 3 are shown in Table 6-5 and Table 6-6 and pictorially in Figure 6-6.

Option 3: Duplexing A & B Option first and 220 kV into Pakuranga				
Transfer Limit (MW)	Year	Augmentation	Type of Project	Reason
2677	2010	Install new BOB 220/110 kV Inter-connector	Modelled	Prevents overload of HAM-BOB circuits in 2011 (during Summer peak condition), during contingency of parallel circuit
2771	2011	Thermally upgrade the 220 kV HAM-HLY-1, HLE-WKM and HAM-WKM-1 circuits (HLE-HAM-WKM section of the OTA-WKM C double circuit line) to 2xGoat 80°C	Modelled	To prevent overloading of the 220 kV HAM-WKM circuit when the HLE-WKM1 circuit is out of service
2780	2012	Build new 220 kV substation at Pakuranga	GIT	
		Install three new 120 MVA supply transformers at PAK	GIT	To prevent Overloading of the 220 kV OTA-PEN-6 circuit when the OTA-PEN-5 circuit is out of service

Option 3: Duplexing A & B Option first and 220 kV into Pakuranga				
Transfer Limit (MW)	Year	Augmentation	Type of Project	Reason
		Partially shift Pakuranga load from 110 kV to 220 kV	-	As ARI-PAK line is in service, part of load can be kept at 110 kV, till the decommissioning of that line
		Increase operating voltage of OTA-PAK 1 and 2 circuits (OTA-PAK A transmission line) to 220 kV	GIT	
		Install 1 st PAK-PEN cable	GIT	To prevent the 220 kV OTA-PEN 5 circuit from overloading for a contingency on the OTA-PEN 6 circuit
3135	2013	Duplex the 220 kV OTA-WKM 1 & 2 circuits (OTA-WKM A and B lines) and re-terminate them (via underground cables) on to the PAK 220 kV bus.	GIT	To prevent overloading of 220 kV HLE-OTA-1 circuit for a HLE-OTA-2 circuit contingency; OTA-WKM 1 & 2 circuits overloads when the Huntly generation is re-dispatched to reduce overloads on HLE-OTA circuits, for a contingency of HAM-WKM circuit
		Install two new 220 kV Cables from OTA-WKM 1 & 2 circuit deviation point to Pakuranga		
	2016	Install 2 nd PAK-PEN cable	GIT	To prevent overloading of the 220 kV PAK-PEN Cable when the 220 kV OTA-PEN 6 circuit is out of service
		Re-conductor ARI-HAM 1 & 2 circuits to Nitrogen 75 deg C	Common Deferred by 3 years	To prevent overloading of the 110 kV ARI-HAM 1 & 2 circuits for a contingency on the 220 kV HAM-WKM-1 circuit.
3441	2017	Bussing the 220 kV OTA-WKM 1 and 2 circuits (OTA-WKM A&B lines that were deviated to PAK in 2014) into HLE	Modelled	To prevent overloading of the 220 kV HLE-OTA 1 circuit for a contingency of the parallel circuit. To prevent overloading of the 220 kV HAM-WKM circuit for a contingency of the HLE-WKM circuit
3369	2019	Install OTA-WIR 110 kV Cable	Common advanced by 2 years	To prevent overloading of the parallel 110 kV OTA-WIR-2 circuit when the parallel BOB-OTA-WIR-1 circuit is out of service

Option 3: Duplexing A & B Option first and 220 kV into Pakuranga				
Transfer Limit (MW)	Year	Augmentation	Type of Project	Reason
		Decommission the 110 kV ARI-PAK Line ¹ and shift all 110 kV PAK load to 220 kV	Modelled	New Line uses this line route
4326	2020	New 220kV double circuit line (Twin Chukar at 75 deg) from WKM and ORM	Modelled	To prevent overloading of HAM-WKM circuit for a contingency on the HLE-WKM circuit
		Install two new 220 kV cables from ORM-PAK	Modelled	
		Install 3 rd PAK-PEN cable	Modelled	To prevent overloading of the remaining PAK-PEN Cable for a contingency of parallel cable
		Build new Cable Transition Station at ORM	Modelled	
4396	2024	Install 2 nd ROS 220/110 kV interconnecting transformer	Common	To prevent overloading of the ROS interconnecting transformer for a contingency of the OTA interconnecting transformer T5
		Re-conductor HAM-BOB 110 kV circuits to Nitrogen Conductors.	Common	To prevent overloading of HAM-BOB 1 circuit for a contingency of the parallel circuit (during Summer Peak period).
	2025	Install a 75 MVA Phase Shifting Transformer on 110 kV ARI-BOB Circuit	Modelled	To limit the overloads on the ARI-BOB circuit for a contingency of HLY-BOB-GLN 220 kV circuit (which also takes out BOB inter connector)
	2027	Install 2 nd PEN-ROS Cable	Common	To prevent overloading of the 220/110 kV OTA interconnecting transformer T5 when the PEN-ROS Cable is out of service.
4784	2031	Install 50% Series Compensation on 220 kV ORM-WKM 1 & 2 circuits.	Modelled	To prevent overloading of the 220 kV HAM-WKM circuit for a contingency of the ORM-WKM 1 or HLE-WKM circuits.
		Build Switching Station at Ormiston Road	Modelled	To prevent overloading of the 220 kV ORM-PAK cables for a contingency of the parallel ORM-PAK Cable
		1 st and 2 nd ORM-OTA 220 kV cable	Modelled	
	2032	Install 3 rd ROS 220/110 kV interconnecting transformer	Common	To prevent overloading of the remaining ROS interconnecting transformer when one of them is out of service

Option 3: Duplexing A & B Option first and 220 kV into Pakuranga				
Transfer Limit (MW)	Year	Augmentation	Type of Project	Reason
5678	2035	New 220kV double circuit line (Twin Chukar at 75 deg) from WKM to a point South of Auckland	Modelled	To prevent overloading of the 220 kV ORM-WKM-2 circuit for a contingency of ORM-WKM-1 circuit
		Install 1 st OTA-PEN Cable	Modelled	To prevent overloading of the 220 KV PAK-PEN 2 & 3 Cables for a contingency of the PAK-PEN 1 circuit
		Install 1 st south of Auckland line termination – OTA Cable	Modelled	To prevent overload of the 220 KV ORM-PAK 1 cable for a contingency on the ORM-PAK 2 circuit
	2037	Install new OTA 220/110 kV interconnecting transformer (similar to T5)	Common	To prevent overloading of the OTA interconnecting transformer T5 for a contingency on the OTA interconnecting transformer T3.
Notes: 1. The ARI-PAK cable tunnel may be needed for other cables and therefore may be decommissioned earlier 2. The capacity of the 220 kV cables from ORM to OTA/PAK mach the capacity of the transmission lines. There is no benefit for installing forced cooling on the cables in this option as it does not provide any additional capacity into the UNI				

Table 6-5: Thermal Development Plan for Option 3 (duplexing first)

Reactive Plan : Option 3 (Deferral of Investment Option)

Year	Location	Quantity (Mvar)	Static/Dynamic*
2008	OTA	250	S
2009	OTA	50	S
2009	OTA	100	D
2015	OTA	100	S
2016	HLY	200	S
2025	HLY	200	S
2025	OTA	100	S
2027	OTA	100	S
2029	OTA	250	S
2033	OTA	150	S
2033	OTA	50	D
2039	OTA	300	S
2042	OTA	450	S
	Total	2300	

* Dynamic requirement for transmission contingency into Auckland ONLY

Table 6-6: Reactive Plan for Option 3 (duplexing first)

NORTH ISLAND GRID UPGRADE PROJECT – AMENDED PROPOSAL
ATTACHMENT D – TECHNICAL ASSESSMENT OF MODIFIED OPTIONS

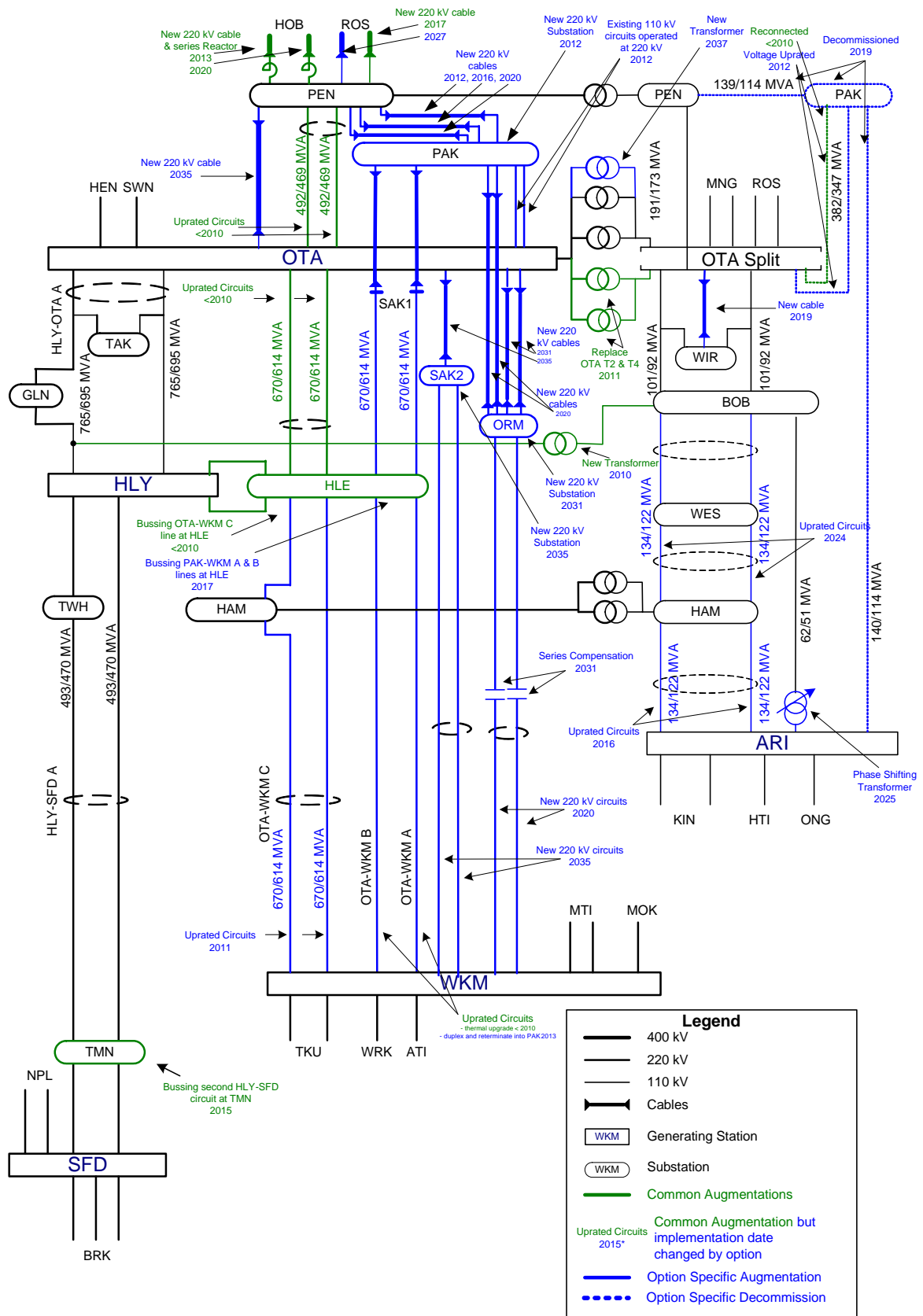

Figure 6-6: Option 3 (duplexing first)

The transfer limit for this option is shown in Figure 6-7.

Option 3 Transfer Limits

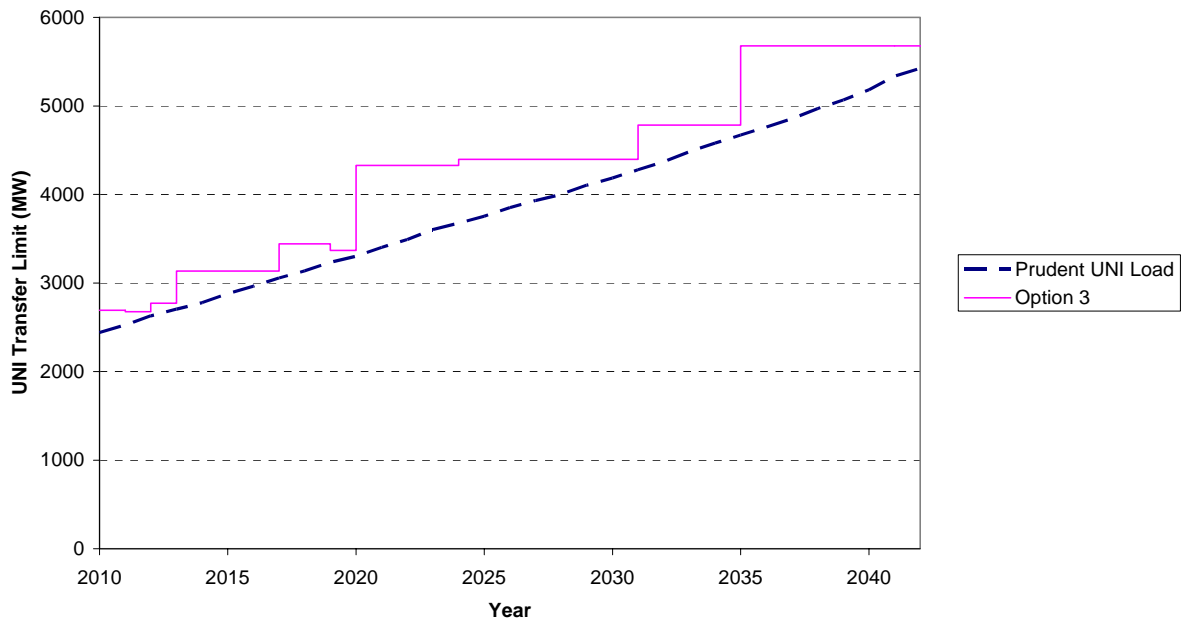

Figure 6-7: Transfer Limits against forecast demand for Option 3.

6.5 Option 4: Replacing existing 220 kV conductors with High Temperature Conductors

This option includes augmenting the existing network in addition to those identified as in Section 5.1 to defer new investment.

Existing conductors on Otahuhu-Whakamaru A, B and C lines are replaced with High temperature conductors.

A new 220 kV double circuit transmission line into Pakuranga will be built when transmission capacity into the UNI is exhausted. This option includes installing series capacitors on the existing re-conducted lines, as well as the new 220 kV line, when needed to increase the transfer capacity into the UNI.

Duplexing the OTA-WKM A & B circuits with HTC in 2013 increases the transfer to approximately 3107 MW.

Other augmentations including series compensation of Otahuhu-Whakamaru A&B lines increases the transfer capacity to approximately 3655 MW.

The Otahuhu-Whakamaru C line is re-conducted with HTC and series compensated. This along with bussing of Otahuhu-Whakamaru A&B lines at HLE, and other augmentations, increases the transfer limit to approximately 4154 MW.

A new 220 kV double circuit line is built in 2029. This along with other augmentations, increases the transfer limit to approximately 5232 MW.

Installing series compensation on the new 220 kV transmission line in 2040 increases the transfer limits to approximately 5581 MW.

The Thermal and the Reactive development plans for Option 3 are shown in Table 6-7 and Table 6-8 and pictorially in Figure 6-8.

Option 4: Duplexing A & B with High temperature conductors				
Transfer Limit (MW)	Year	Augmentation	Type of Project	Reason
2677	2010	Install BOB 220/110 kV inter-connector	Modelled	Prevents overloading of HAM-WES and BOB-WES circuits
	2011	Thermally upgrade the 220 kV HAM-HLY-1, HLE-WKM and HAM-WKM-1 circuits (HLE-HAM-WKM section of the OTA-WKM C double circuit line) to 2xGoat 80°C	Modelled	Prevents overloading of the 220 kv HAM-WKM-1 circuit when HLE-WKM-1 circuit is out of service
	2012	Build new 220kV substation at PAK.	GIT	To prevent overloading of 220 kV OTA-PEN-6 when OTA-PEN-5 is

Option 4: Duplexing A & B with High temperature conductors				
Transfer Limit (MW)	Year	Augmentation	Type of Project	Reason
		Install three new 120MVA 220/33 kV supply transformers at PAK		out of service. Pakuranga load partially retained on 110 kV as ARI-PAK 110 kV line is in service
		Increase operating voltage of OTA-PAK 1 and 2 circuits (OTA-PAK A transmission line) to 220kV		
		Partially shift Pakuranga load from 110kV to 220kV		
		Install 1 st PAK-PEN cable		
3107	2013	Re-conductor OTA-WKM 1 & 2 circuits (OTA-WKM A and B lines) with HTC Duplex and re-terminate them (via underground cables) on to the PAK 220 kV bus.	GIT	Prevents overloading of OTA-HLE 1 during outage of OTA-HLE 2
		Install two new 220 kV cables from OTA-WKM 1 & 2 circuits deviation point to Pakuranga		
	2015	Install 2 nd PAK-PEN cable	GIT	To prevent overloading of the 220 kV OTA-PEN 5 and 6 circuits when PAK-PEN cable outages out of service; and To prevent overloading of 220 kV PAK-PEN cable when OTA-PEN 5 is out of service
	2016	Re-conductor ARI-HAM 1 & 2 circuits to Nitrogen at 75 deg C	Modelled	To prevent overloading of the 110 kV ARI-HAM 1 and 2 circuits when 220 kV HAM-WKM-1 is out of service
3655	2017	Install 40% series compensation on the OTA-WKM 1 & 2 circuits (OTA-WKM A and B lines)	Modelled	To prevent overloading of the 220 kV HLE-OTA 1 circuit for a contingency of the parallel circuit.
	2019	Install OTA-WIR 110 kV	Modelled	Top prevent overloading of the

Option 4: Duplexing A & B with High temperature conductors				
Transfer Limit (MW)	Year	Augmentation	Type of Project	Reason
		cable		110 kV OTA-WIR-2 circuit when the parallel BOB-OTA-WIR-1 circuit is out of service
		Build switching station at WIR		
	2019	Reconnect the two disconnected lines from SAK to OTA (existing overhead section) as a bonded pair	Modelled	To prevent overloading of the 220 kV PAK-PEN and PAK-SAK cables for a contingency in parallel cables
		Build new switching station at SAK		
4154	2023	Re-conductor 220 kV OTA-WKM C line with Duplex HTC (all sections except HLE to HAM section)	Modelled	To prevent overloading of the remaining 220 kV OTA_WKM 1 & 2 circuits for a contingency of a parallel circuit To prevent heavy loading (99.5%) of the remaining OTA-HLE section of the OTA-WKM C line during a contingency of the parallel circuit
		Install 25% series compensation on OTA-HLE-1 and 2 circuits, and HLE-WKM-1 circuits (OTA-HLE and HLE-WKM sections of OTA-WKM C line)		
		Install 30% series compensation on 220 kV HAM-WKM-1 circuit (HAM-WKM section of OTA-WKM C line)		
		Reduce series compensation on OTA_WKM 1 and 2 circuits to 25%		
		Buss OTA-WKM 1 & 2 circuits (OTA-WKM A and B lines) at HLE		
		Install 1 st Cable from OTA to PEN	Modelled	To prevent overloading of remaning PAK-PEN cable during outage of one of the PAK-PEN cables
	2024	Install 2 nd ROS 220/110 kV interconnecting transformer	Common	To prevent overloading of the remaining ROS interconnecting transformer when OTA T5 is out of service.

Option 4: Duplexing A & B with High temperature conductors				
Transfer Limit (MW)	Year	Augmentation	Type of Project	Reason
		Re-conductor 110 kV BOB-HAM circuits with Nitrogen conductor	Common	To prevent overloading of these circuits for a contingency (Summer High).
	2025	Install one 75 MVA Phase Shifting Transformer on the 110 kV ARI-BOB-1 circuit	Modelled	To limit the overloads on the ARI-BOB circuit for a contingency of HLY-BOB-GLN 220 kV circuit (which also takes out BOB inter connector)
	2027	Install 2 nd PEN-ROS Cable	Common	To prevent overloading of the OTA interconnecting transformer T5 when the 220 kV PEN-ROS Cable is out of service.
	2028	Decommission the 110 kV ARI-PAK line and shift remaining PAK 110kV load to 220kV	Modelled	New line uses this route
		Install 1 Ohm series reactor on OTA-SAK bonded pair	Modelled	To prevent overloading of SAK_OTA circuit during SAK_PAK outage
	2029	Build new 220 kV double circuit line (twin Chukar at 75 deg) from WKM to ORM	Modelled	To prevent overloading of the southern sections of OTA-WKM A,B,C circuit following a contingency in one of the OTA-WKM A,B and C circuits
		Install two new 220 kV cables from ORM to PAK		
4618	2030	Install 2 nd Cable from OTA to PEN	Modelled	To prevent overloading of the remaining PAK PEN Cable when the other PAK-PEN cable is out of service
5116	2032	Build Switching Station at ORM	Modelled	To prevent overloading of remaining PAK PEN cable when the other PAK-PEN cable is out of service
		Install new 220 kV cable from ORM to OTA		
		Install 3 rd ROS 220/110 kV interconnecting transformer	Common	To prevent overloading of the remaining ROS interconnecting transformer when one of them is out of service
	2037	Install new OTA 220/110kV interconnecting transformer (similar to T5)	Modelled	To prevent overloading of the OTA interconnecting transformer T5 for a contingency on the OTA interconnecting transformer T3.
5232	2039	Install 2 nd cable from ORM to OTA	Modelled	To prevent overloading of the remaining PAK PEN Cable when the other PAK-PEN cable is out of

Option 4: Duplexing A & B with High temperature conductors				
Transfer Limit (MW)	Year	Augmentation	Type of Project	Reason
				service
5581	2040	Install 30% series compensation on ORM-WKM circuits	Modelled	To prevent overloading of the 220 kV circuits between HLE and WKM following a contingency of one of these circuits
		Install 3 rd Cable from PAK to PEN	Modelled	To prevent overloading of the remaining PAK PEN Cable when the other PAK-PEN cable is out of service

Table 6-7: Thermal Development Plan for Option 4 (HTC)

Reactive Plan : Option 4 (High temperature conductor)

Year	Location	Quantity (Mvar)	Static/Dynamic*
2008	OTA	250	S
2009	OTA	100	D
2011	OTA	150	S
2016	HLY	100	S
2019	OTA	150	S
2021	HLY	200	S
2022	OTA	350	S
2023	HLY	200	S
2027	OTA	250	S
2027	HLY	200	S
2035	OTA	150	S
2039	OTA	450	S
2039	OTA	150	D
2041	OTA	250	D
2041	OTA	500	S
	Total	3450	

* Dynamic requirement for transmission contingency into Auckland ONLY

Table 6-8: Reactive Plan for Option 4 (HTC and duplexing first)

NORTH ISLAND GRID UPGRADE PROJECT – AMENDED PROPOSAL
ATTACHMENT D – TECHNICAL ASSESSMENT OF MODIFIED OPTIONS

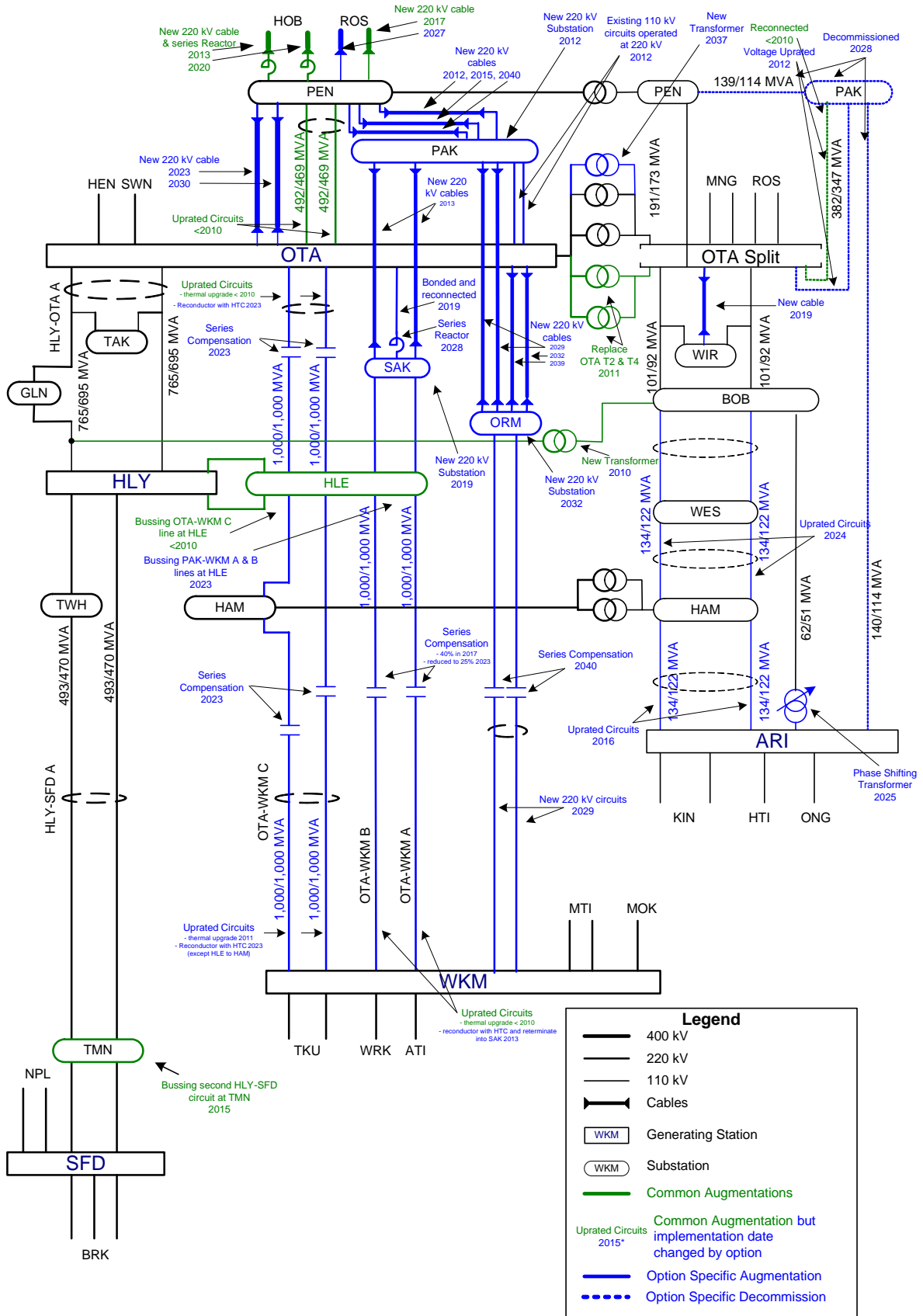

Figure 6-8: Option 4 (HTC and duplexing first)

The transfer limit for this option is shown in Figure 6-9.

Option 4 Transfer Limits

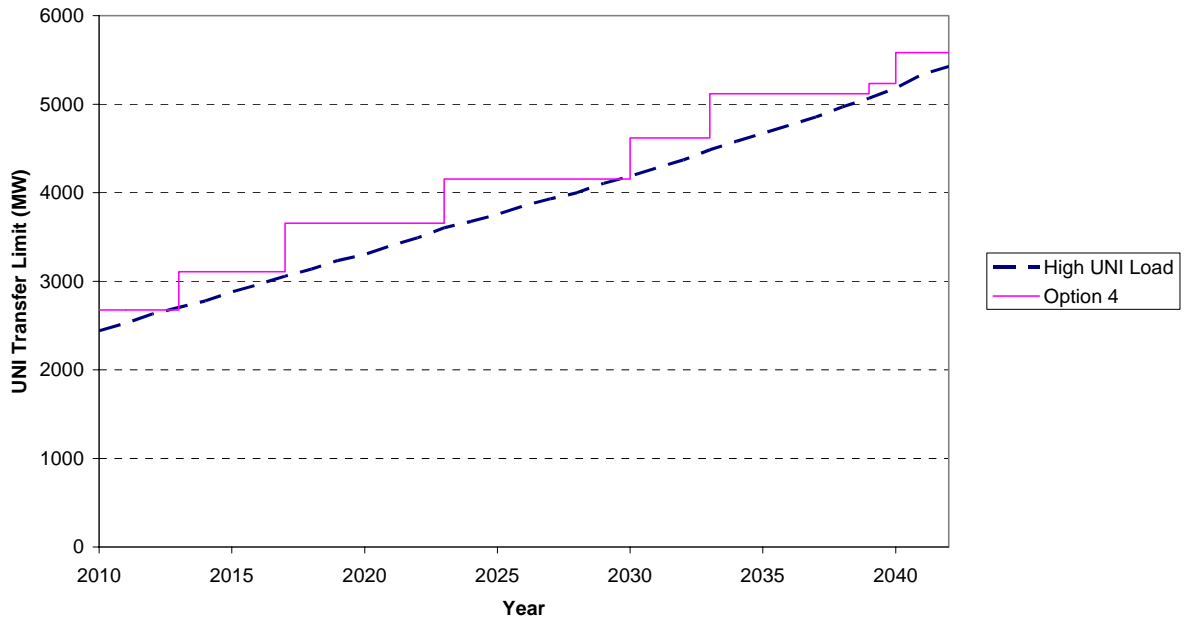

Figure 6-9: Transfer Limits against forecast demand for Option 4.

6.6 Transmission Losses

This section describes the comparison of transmission losses for the alternative transmission options.

The transmission losses are calculated for Winter Peak demand with all the assets in service, including the Otahuhu CCGT. The years have been modified to approximately represent the corresponding year in the Prudent demand forecast. For the purpose of comparison, only the transmission losses associated with the transmission circuits (including 220 kV circuits from Huntly, 110 kV circuits between Arapuni and Otahuhu and the new builds) between Whakamaru and Otahuhu are shown. The transmission losses in the rest of the transmission system are approximately the same for all the transmission options.

The transmission losses for the four options analysed are shown in Figure 6-10. The results shows that while the losses the transmission circuits increases quadratically as the flow through the circuits increases, step reduction in losses could be achieved by investment in transmission (e.g. conversion to 400 kV operation in 2033 (Option 2) or construction of a second 220 kV double circuit transmission line in 2031 (Option 1))

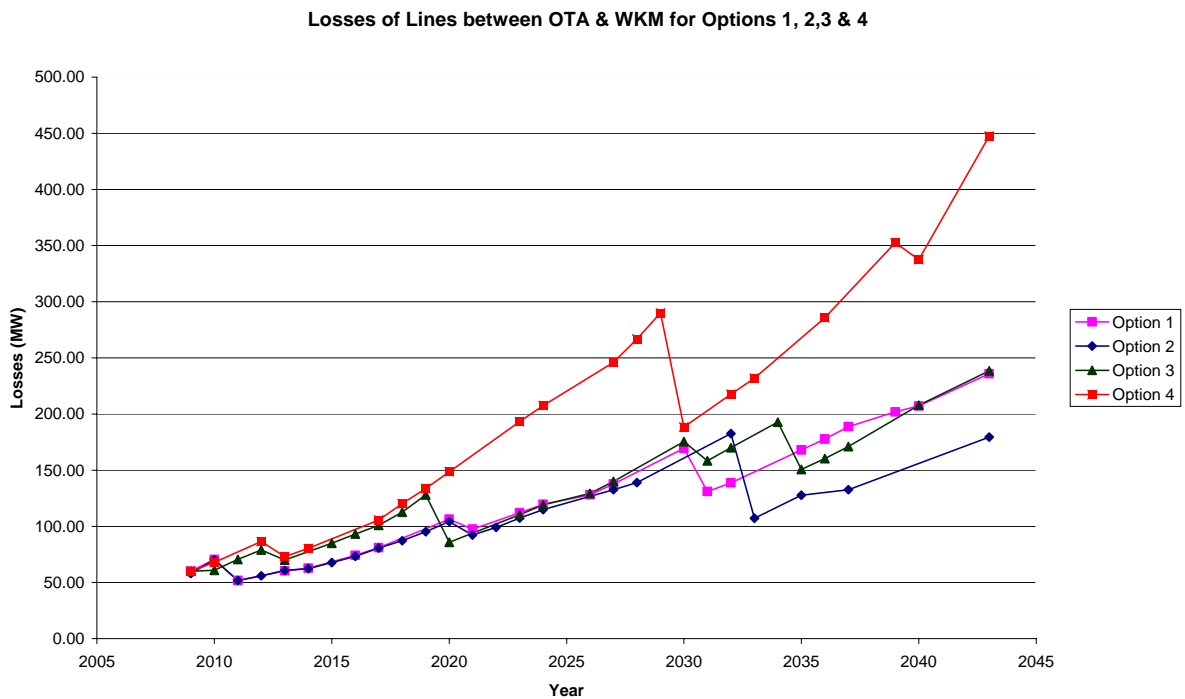

Figure 6-10: Transmission Losses for options considered (in Otahuhu-Whakamaru corridor) for winter peak load

6.7 Reactive Plan

The reactive power losses in the power system increase quadratically as the loading in the transmission circuits are increased. The reactive power losses in the transmission circuits are supplied from the two ends of each transmission circuit. Generally a higher amount of reactive power needs to be supplied from the receiving end compared to the sending end.

The sending end reactive power requirements are assumed to be supplied from the generators at or around Whakamaru. The reactive power available from the generators assumed (as per the generation scenario) is sufficient to provide this reactive requirement. On the other hand, the assumed level of reactive power available at or around Otahuhu is insufficient to meet the reactive power losses in the transmission system by 2010.

The additional reactive support required at Otahuhu end (and at Huntly where appropriate) for the three transmission options are shown in Figure 6-11.

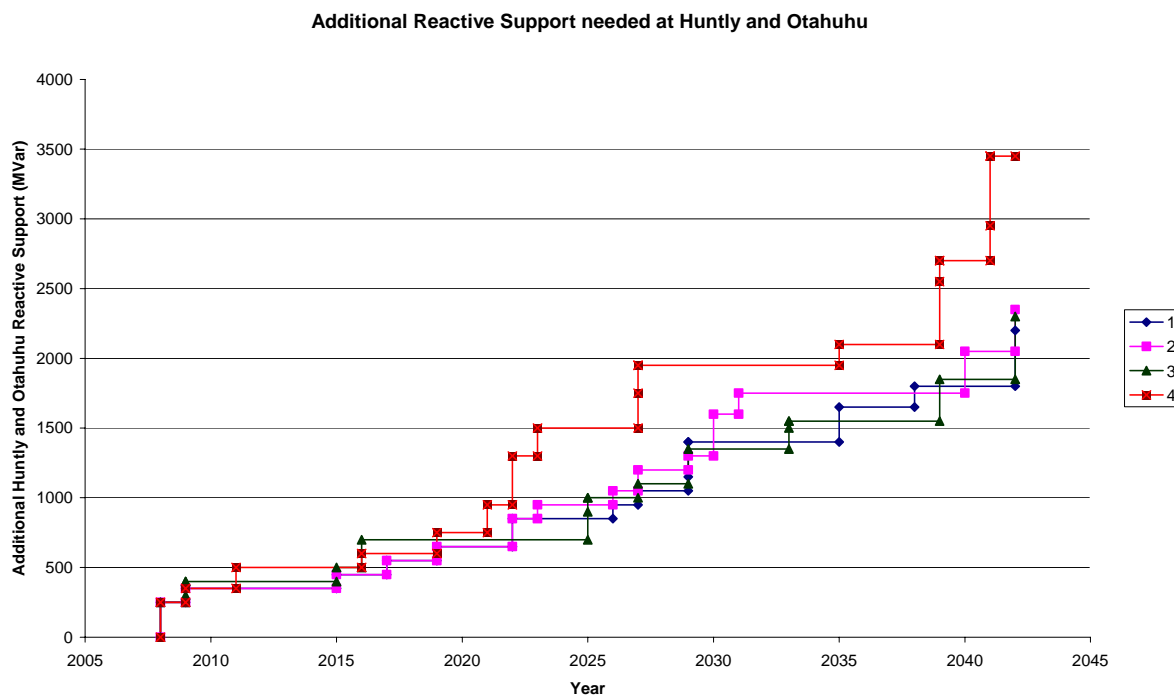

Figure 6-11: Reactive Support requirement at Otahuhu and Huntly

6.7.1 Dynamic Reactive Requirement for Transmission line contingency

The reactive power loss in the transmission system between Otahuhu and Whakamaru undergoes a significantly large step change following an outage of a transmission circuit. In a voltage stability constrained system such as the power system supplying the UNI regions, it is not prudent to rely on post-contingency switching of the capacitor banks for ensuring system stability. It is considered good industry practice to carry sufficient dynamic reserves in the system, pre-contingency, to cater for such events. The dynamic reactive power reserves can be maintained in the form of reactive power from synchronous generators, synchronous condensers, SVCs and thyristor switched capacitors.

In analysing the dynamic reactive power reserves required in UNI region for power transmission between Otahuhu & Whakamaru, the total reactive power sent into the transmission system from Otahuhu and Whakamaru under the worst contingency is assessed both pre and post-contingency. The reactive power difference between the pre and post-contingency situation represents the minimum level of dynamic reactive reserves required at the two ends.

The dynamic reactive power requirement calculation for Option 1, 2, 3 and 4 are shown in Figure 6-12, Figure 6-13, Figure 6-14 and Figure 6-15. The years have been modified to approximately represent the corresponding year in the 10% POE demand forecast, as the analysis was done using a different set of demand forecasts.

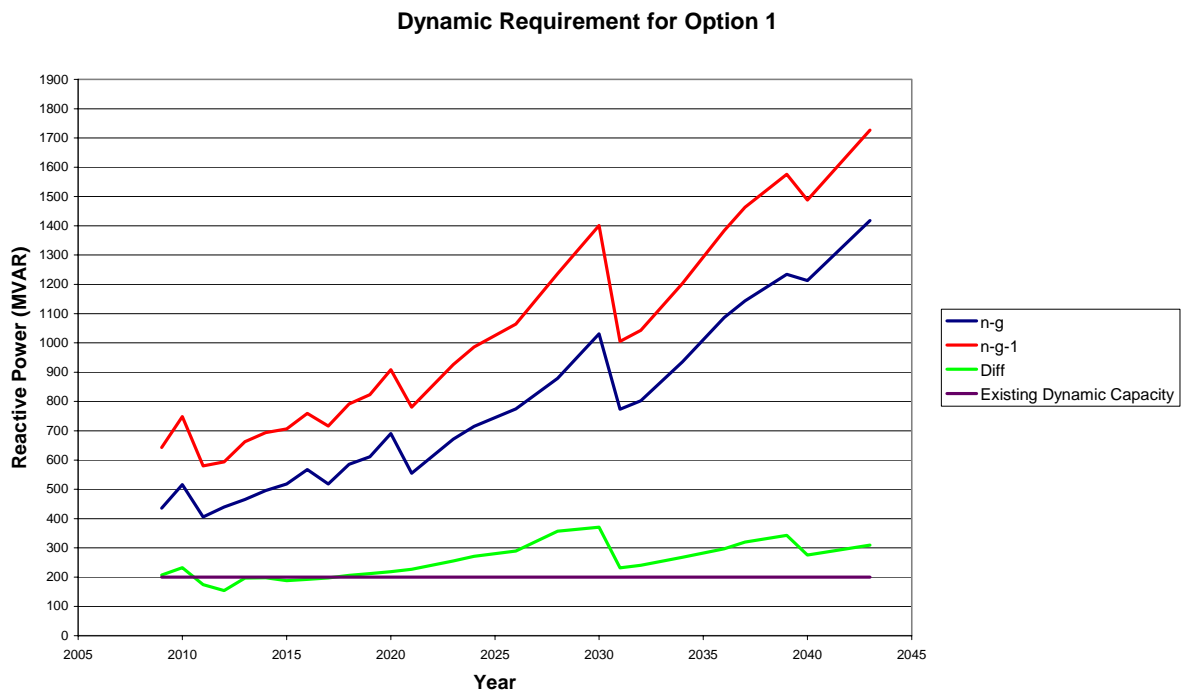

Figure 6-12: Dynamic reactive requirement at Otahuhu for Option 1

Dynamic Requirement for Option 2

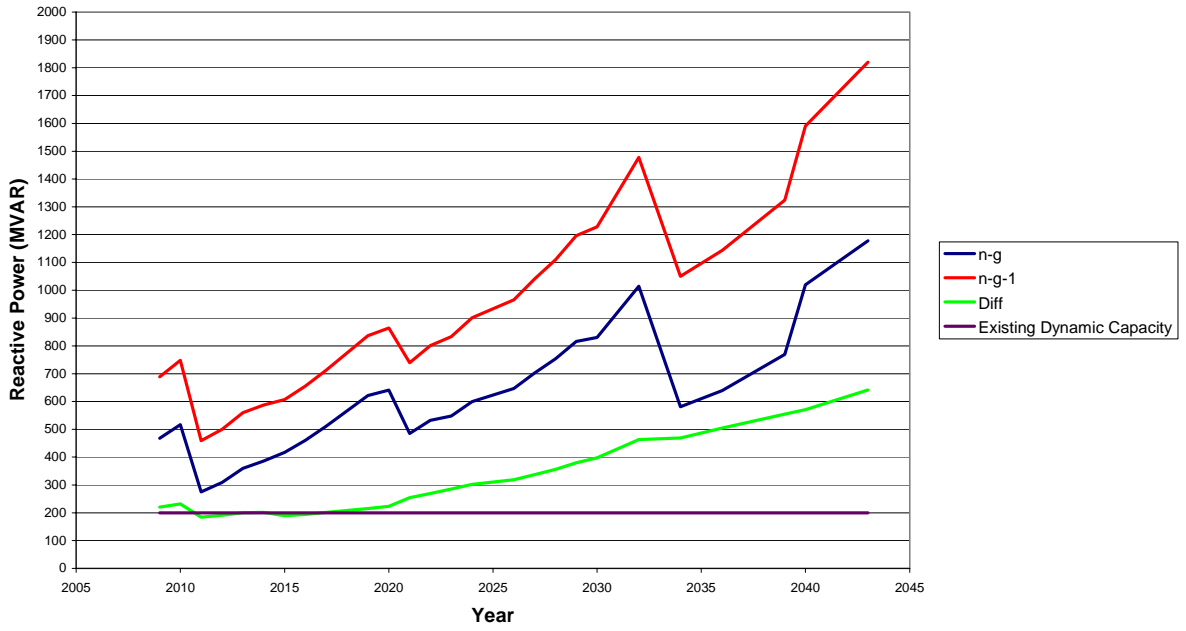

Figure 6-13: Dynamic reactive requirement at Otahuhu for Option 2

Dynamic Requirement for Option 3

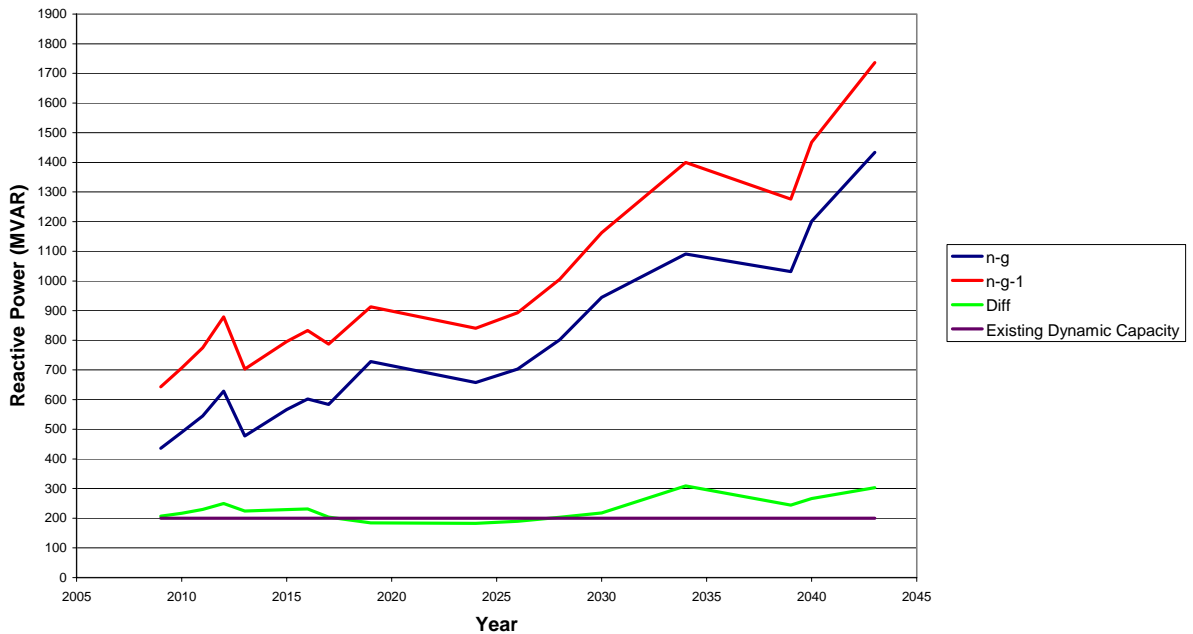

Figure 6-14: Dynamic reactive requirement at Otahuhu for 220 kV Option 3

Dynamic Requirement for Option 4

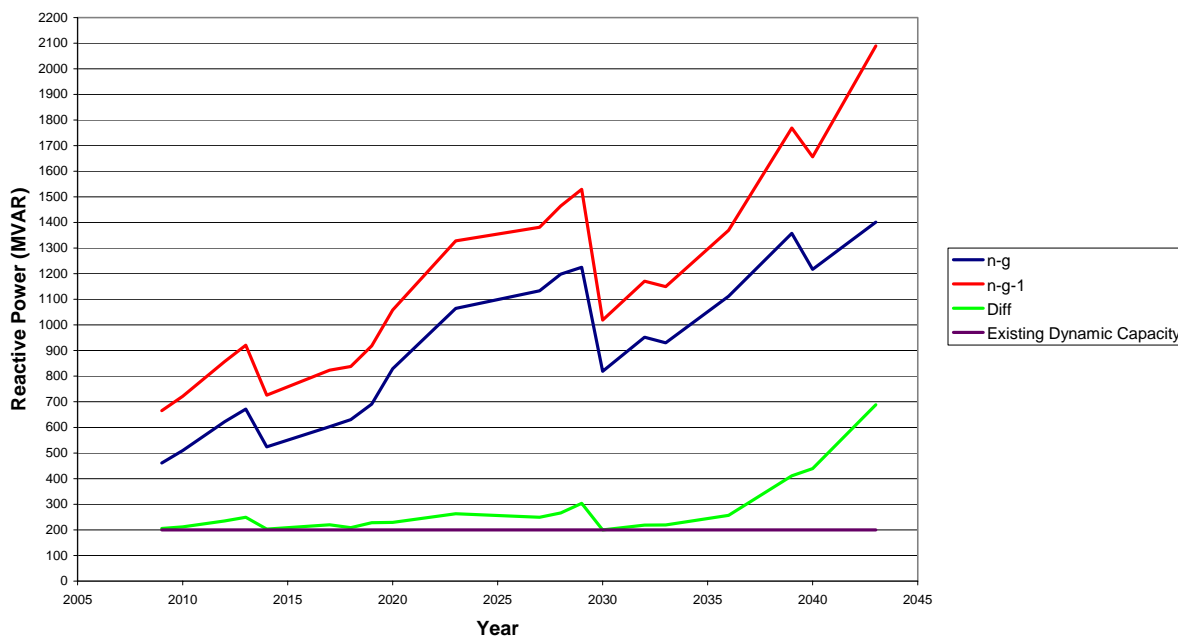

Figure 6-15: Dynamic reactive requirement at Otahuhu for 220 kV Option 4

By 2010, it is likely that the dynamic reactive support in the Otahuhu area will be supplied from two sources, synchronous condensers (3x33 Mvar + 2x50 Mvar) and the Southdown generator (70 Mvar). The synchronous operation of the generators at leading power factors is less stable compared to their operation at lagging power factors. Therefore the reactive power reserves available from the generating units will be significantly less than the maximum reactive output capability of the units. Hence the net value of reactive reserves available at Otahuhu, pre-contingency is likely to be approximately 200 Mvar mainly attributed to the Otahuhu synchronous condensers. This estimated presently available dynamic reactive reserves at Otahuhu is also shown in the figure for comparison.

6.8 Short Term Augmentation Projects

There are a number of options available for the short term deferment of a major grid investment. The options could increase the transmission capacity to the UNI and defer the need for a major transmission investment by approximately 1 - 3 years. The options are summarised in the Table 6-9.

The Phase Shifting Transformers in the transmission lines connecting to Arapuni are likely to be installed at the terminal substations and resource consents are not expected to be a problem. However, thermal upgrading of the OTA-WKM C line may require minor modifications to a limited number of the existing towers, and some easement acquisition may be required. The Drury switching station is ideally located nearer to the Glenbrook deviation of the HLY-OTA line. However the exact location of the switching station is likely to be determined by the availability and acquisition of a suitable property for the station and other resource consent constraints. The effectiveness of the development (in terms of the increased transfer capacity to UNI) is dependent on the location of the switching station.

The preferred short term development will be determined by the transmission capacity increase it will provide, the project risks associated with its implementation and the cost of investment required. These factors will be taken into account by the Grid Investment Test used to select the most economical short-term augmentation option(s).

Assumptions

- 2010 High demand used as base and the loads scaled to obtain transfer limit (Huntly Generation re-dispatched to get maximum limit)
- Arapuni Generation dispatch at 180 MW
- Huntly East (Ohinewai) switching station commissioned OTA-WKM A&B lines thermally upgraded to 75 degrees
- HVDC dispatch at 1400 MW
- PSTs set to have 95% flow post contingency where possible on 110 kV circuits out of ARI, phase shift range +/-30°
- PSTs set to have 100% flow post contingency on 220 kV circuits
- Southdown generation is assumed to be 120 MW. The new Southdown generation to be commissioned in late 2006 will increase the transfer capacity shown in the following table by approximately 50 MW.
- New Plymouth generation is assumed to be 180 MW. Any increase in the dispatched generation from New Plymouth is likely to increase the transfer limit (by approximately 15 MW for every 100 MW generation increase from NPL).
- Transfer Limits quoted are approximate values and the accuracy may vary slightly due to the numerical algorithms used

SI	Description	ARI-PAK in	ARI-PAK out	Comment
		UNI Transfer Capacity(MW)		
1	Base system (as per the above assumptions)	2668	2510*	
2	PSTs on HLE-OTA 1 & 2 Circuits	Very small change	Very small change	By itself, this project has marginal impact on the transfer capacity
3	Thermal upgrade of OTA-WKM C line upgrade to 80 deg	Very small change	Very small change	By itself, this project has marginal impact on the transfer capacity
4	PSTs on HLE-OTA 1 & 2 + OTA-WKM C line upgrade	2753 ¹	2667 ¹	700 MVA PSTs required. Increases transfer from Tranaki and Huntly as well as from Whakamaru. However, if the generation south of Whakamaru is replaced from central North island generation, the transfer limit is likely to reduce.
5	PSTs on ARI-HAM, ARI-BOB AND ARI-PAK+OTA-WKM C line upgrade	2711	2618	Increases the transfer from Whakamaru to UNI. With ARI-PAK in service, the circuits into ARI from the south particularly KIN-LFD will overload for a HAM-WKM outage. Overloading (up to approx 165%) as far back as TRK ICTs, no overloading without ARI-PAK in service

		ARI-PAK in	ARI-PAK out	
6	Re-conductoring of HAM-BOB circuits + PSTs as in 5 + OTA-WKM C line upgrade	2707	2623	Increases the transfer from Whakamaru to UNI. With ARI-PAK in service, the circuits into ARI from the south particularly KIN-LFD will overload for a HAM-WKM outage. Overloading (up to approx 165%) as far back as TRK ICTs, no overloading without ARI-PAK in service
7	Drury switching station	2665¹	2659¹	Increases transfer from Tranaki and Huntly However, if the generation south of Whakamaru is replaced from the Central North Island generation then the transfer limit drops substantially. Low Huntly generation will also have a similar effect,
8	Drury switching station + OTA-WKM C line upgrade	2764¹	2736¹	Increases transfer from Tranaki and Huntly as well as from Whakamaru. However, if the generation south of Whakamaru is replaced from the Central North Island generation then the transfer limit is likely to reduce.
9	Re-conductoring of ARI-PAK+PST on ARI-PAK +OTA-WKM C line upgrade	2751	-	The 110 kV circuits between Kingleith and Tarukenga and inter connector at Tarukenga overload up to approx 160% and needs augmentation
10	OTA-WKM C line upgrade, Drury switching station, Re-conductor ARI-PAK and HAM-BOB, PSTs on all 110 kV circuits north of ARI	2805	2724	The 110 kV circuits between Kingleith and Tarukenga and inter connector at Tarukenga overload up to approx 200%, where ARI-PAK is in service and needs augmentation
11	OTA-WKM C line upgrade, Drury switching station, Re-conductor ARI-PAK and HAM-BOB, PSTs on all 110 kV circuits north of ARI, PSTs on HLE-OTA circuits	2879	2803	The 110 kV circuits between Kingleith and Tarukenga and inter connector at Tarukenga overload up to approx 205%, where ARI-PAK is in service and needs augmentation
<p>Notes:</p> <p>1. BOB-WIR-OTA circuit breakers are open at BOB to prevent overloading on the HAM-BOB circuits reducing the transfer limit</p>				

Table 6-9: Short Term Augmentation Plan

7 Conclusion

Four transmission options based on the original submission in the Grid Upgrade Plan (2005) were further developed and analysed. The modified transmission plans improve the physical diversity provided by the transmission system supplying the UNI, making the power supply more resilient for rare but high impact disturbances. Market benefits provided by each of the option were increased by deferring the investments required as long as possible and making the maximum utilisation of the existing transmission assets.

The four transmission options encompass different strategic high voltage ac transmission development approaches to enhance the transmission capacity into the UNI. The three options are:

1. New 220 kV transmission into the UNI
2. New 400 kV transmission into the UNI (initially operated at 220 kV):
3. Augmentation of the existing 220 kV transmission system into the UNI
4. Replacing Existing 220 kV conductors with High Temperature Conductors

A deterministic grid reliability criteria was assumed for planning the transmission grid. The grid is planned to provide the supply reliability to the loads for an outage of one transmission element together with an outage of a major generating unit in the UNI (i.e. n-g-1). The transmission plans developed for all the options satisfy the assumed grid reliability criteria.

A new 220 kV double circuit transmission line is required to be built by 2011 in option 1. The new transmission line reaches its capacity by 2031 and the transmission capacity needs to be augmented by building another 220 kV double circuit transmission line.

A new 400 kV double circuit transmission line is required to be built by 2011 in option 2. The line will be initially operated at 220 kV and the operating voltage will be updated to 400 kV in 2033. The capacity of the transmission line is sufficient to meet the forecast prudent demand until 2042.

Construction of a new line can be deferred until 2020 by making a number of incremental upgrades to the existing transmission system (option 3). The major incremental upgrades required include:

- re-terminating, duplexing and bussing at Huntly East of the existing Otahuhu-Whakamaru A & B lines,
- temperature uprating of the Otahuhu – Whakamaru C line, and
- providing a 220kV/110 kV interconnecting transformer at Bombay.

Option 4 includes replacing the existing conductors on Otahuhu-Whakamaru A, B and C lines with High temperature conductors and series compensated when required. The Otahuhu-Whakamaru A and B lines are re-terminated into a point south of Auckland with 220 kV underground cables to Pakuranga. A new 220 kV line will be built when capacity is exhausted in 2029.

The transmission losses for Option 4 are the highest of all the options considered. Towards the end of the planning period, the transmission losses in the Whakamaru – Otahuhu corridor, for this option, amount to approximately 450 MW at winter peak, which is approximately 100% higher than the other options. The reactive power requirements for Option 4 are also significantly higher than for other options. Towards the end of the planning period, the total reactive power requirement for Option 4 is approximately 1,000 Mvar higher than the other options.

Reactive support is planned as required to meet the reactive power losses in the transmission system. The planned reactive support will ensure voltage stability of the power system, allowing for a 5% load margin, to accommodate any modelling uncertainties. Dynamic reactive power support is planned such that sufficient reactive reserves are maintained within the dynamic plants (generators, synchronous condensers and SVCs) so that post contingency capacitor switching is not required.

Detailed staged transmission plans have been developed for the four transmission options.

Appendix A Substation Three-Letter Codes

Short Code	Site	Short Code	Site	Short Code	Site	Short Code	Site
ABY	Albury	HEN	Henderson	MTR	Mataroa	TAK	Takanini
ADD	Addington	HEP	Hepburn Road	NMA	North Makarewa	TAP	Te Apati
ALB	Albany	HIN	Hinuera	NPK	National Park	TCC	Taranaki Combined Cycle
ALD	Arnold	HKK	Hokitika	NPL	New Plymouth	TGA	Tauranga
ANC	Anchor Products (Te Awamutu)	HLE	Huntly East (Ohinewai)	NSY	Naseby	TIM	Timaru
ANI	Aniwhenua	HLY	Huntly	OAM	Oamaru	TKA	Tekapo A
APS	Arthur's Pass	HOR	Hororata	OHA	Ohau A	TKB	Tekapo B
ARA	Aratiatia	HPI	Huapai	OHB	Ohau B	TKH	Te Kaha
ARG	Argyle	HTI	Hangatiki	OHC	Ohau C	TKR	Takapu Road
ARI	Arapuni	HUI	Huirangi	OHK	Ohakuri	TKU	Tokaanu
ASB	Ashburton	HWA	Hawera	OKE	Okere	TMH	Three Mile Hill
ASY	Ashley	HWB	Halfway Bush	OKI	Ohaaki	TMI	Te Matai
ATI	Atiamuri	IGH	Inangahua	OKN	Ohakune	TMK	Temuka
AVI	Aviemore	INV	Invercargill	ONG	Ongarue	TMN	Taumarunui
BAL	Balclutha	ISL	Islington	OPI	Opihi	TMU	Te Awamutu
BDE	Brydone	KAI	Kaiapoi	OPK	Opunake	TNG	Tangiwai
BEN	Benmore	KAW	Kawerau	OPU	Opuha	TOB	Tokomaru Bay
BLN	Blenheim	KEN	Kensington	ORM	Ormiston Road (400 kV Cable-Line interface)	TRK	Tarukenga
BOB	Bombay	KIK	Kikiwa	ORO	Orowaiti Tee	TUI	Tuai
BPE	Bunnythorpe	KIN	Kinleith	OTA	Otahuhu	TVT	Teviot
BRB	Bream Bay	KKA	Kaikoura	OTB	Oteranga Bay	TWH	Te Kowhai
BRK	Brunswick	KOE	Kaikohe	OTC	Otahuhu CC	TWI	Tiwai
BRR	Branch River	KPI	Kapuni	OTG	Otahuhu Power Station	TWZ	Twizel
BRY	Bromley	KPO	Karapiro	OTI	Otira	UHT	Upper Hutt
BWK	Berwick	KPU	Kopu	OWH	Owhata	UTK	Upper Takaka
CBG	Cambridge	KTA	Kaitaia	PAK	Pakuranga	WAA	Whareroa
CLH	Castle Hill	KUM	Kumara	PAL	Palmerston	WAH	Wahapo
CML	Cromwell	KWA	Kaiwharawhara	PAP	Papanui	WAI	Waiotahi
COB	Cobb	LFD	Lichfield	PEN	Penrose	WDV	Woodville
COL	Coleridge	LIV	Livingstone	PKE	Poike	WEL	Wellsford
CPK	Central Park	LTN	Linton	PNI	Pauatahanui	WES	Western Road
CST	Carrington Street	MAN	Manapouri	PPI	Poihipi	WGN	Wanganui
CUL	Culverden	MAT	Matahina	PRM	Paraparaumu	WHE	Wheao
CYD	Clyde	MCH	Murchison	PTA	Patea	WHI	Whirinaki
DAR	Dargaville	MDN	Marsden	RDF	Redclyffe	WHU	Waihou
DOB	Dobson	MGM	Mangamaire	RFT	Reefton	WIL	Wilton
DVK	Dannevirke	MHO	Mangahao	ROB	Robertson Street	WIR	Wiri
EDG	Edgecumbe	MLG	Melling	ROS	Mount Roskill	WKM	Whakamaru
EDN	Edendale	MNG	Mangere	ROT	Rotorua	WKO	Waikino
FHL	Fernhill	MNI	Motunui	ROX	Roxburgh	WMG	Waimangaroa
FKN	Frankton	MOK	Mokai	RPO	Rangipo	WPA	Waipapa
GFD	Gracefield	MOT	Motueka	RTR	Retaruke	WPI	Waipori
GIS	Gisborne	MPE	Maungatapere	SBK	Southbrook	WPR	Waipara
GLN	Glenbrook	MPI	Motupipi	SDN	South Dunedin	WPT	Westport
GOR	Gore	MRA	Moturoa	SFD	Stratford	WPW	Waipawa
GYM	Greymouth	MST	Masterton	SPN	Springston	WRA	Wairoa
GYT	Greytown	MTI	Maraetai	STK	Stoke	WRK	Wairakei
HAM	Hamilton	MTM	Mt Maunganui	STU	Studholme	WTK	Waitaki
HAY	Haywards	MTN	Marton	SVL	Silverdale	WTU	Whakatu
HBK	Highbank	MTO	Maungaturoto	SWN	Southdown	WVY	Waverley

Table A.1: Site Abbreviations

Appendix B Electrical Parameters (Options 1-4)

400kV Double Circuit Line ORM-WKM

Type : Triplex Sulphur (AAAC)
Rating 2700/2462 MVA winter/summer at 75 deg
Length 186.5 km
R1 = 2.7639 ohms
X1 = 51.2095 ohms
C1 = 2.4994 microfarads

220kV Double Circuit Line ORM-WKM

Type Duplex Chukar ACSR-GZ
Rating 1237/1124 MVA winter/summer at 75 deg
Length 186.5 km
R1 = 2.9311 ohms
X1 = 50.8026 ohms
C1 = 2.3499 microfarads

220kV Cable

Type 2500 sq mm copper
Rating 668 MVA
With forced Cooling 1115 MVA (Winter)
R1 = 0.0099 ohms/Km
X1 = 0.1656 ohms/Km
C1 = 0.274 microfarads/Km

Cable Lengths

ORM-OTA : 8.4 Km
ORM-PAK : 8.17 Km
PAK-PEN : 9.1 Km
OTA-PEN : 8.63 Km
SAK-PAK : 11.67 Km

220kV Duplex Goat from WKM-SAK (South Auckland)

Type Duplex Goat
Rating 670/614 MVA at 80 deg
Length 185 km
R1 = 8.2288 ohms
X1 = 53.3355 ohms
C1 = 2.2922 microfarads

220kV Duplex Goat from WKM-HLE

Type Duplex Goat
Rating 670/614 MVA at 80 deg
Length 118.2 km
R1 = 5.2575 ohms
X1 = 34.0771 ohms
C1 = 1.4645 microfarads

220kV Duplex Goat from HLE-SAK (South Auckland)

Type Duplex Goat

Rating 670/614 MVA at 80 deg
Length 66.8 km
R1 = 2.9713 ohms
X1 = 19.2584 ohms
C1 = 0.8277 microfarads

Series Capacitors on New OTA-WKM 400kV Lines

Maximum line load 2700 MVA (3.911 kA)
Capacitive reactance 28.16 ohms (55% of line reactance)
Reactive power at full load 1292 Mvar

Series Capacitors on New OTA-WKM 220kV Lines

Maximum line load 1237 MVA (3.241 kA)
Capacitive reactance 25.4013 ohms (50% of line reactance)
Reactive power at full load 801 Mvar

400/220 kV Transformer

Rating: 600 MVA
Overload capacity (24 hour rating): 116.67%
Voltage ratio: 400/220 kV
Reactance: 10%
R/X: 0.01

110 kV ARI-HAM circuit re-conductor

Conductor : Nitrogen
Length : 47 Km
Rating : 134/126 MVA for Winter/Summer
R1=5.405 ohms
X1=18.19 ohms
C1=0.4465 microfarads

110 kV HAM-BOB circuit re-conductor

Conductor : Nitrogen
Length : 74.5 Km
Rating : 134/126 MVA for Winter/Summer
R1=8.5675 ohms
X1=28.83 ohms
C1=0.7078 microfarads

110 kV PSTs

Rating : 75 MVA
Voltage ratio : 110/110 kV
% Impedance : 10%
R/X = 0.035

Series Reactors on OTA-WKM A&B Circuits

- 20 ohms (Option 2)
- 15 ohms (Option 1)

Current rating: 848 Amps

220kV Duplex HTC(High temperature conductor) from WKM-SAK (South Auckland)

Rating 1000/1000 MVA
Length 185 km
R1 = 7.90 ohms
X1 = 59.21 ohms
C1 = 2.18 microfarads

220kV Duplex HTC from HLE-SAK (South Auckland)

Rating 1000/1000 MVA
Length 66.80 km
R1 = 2.90 ohms
X1 = 19.96 ohms
C1 = 0.850 microfarads

220kV Duplex HTC from HLE-OTA

Rating 1000/1000 MVA
Length 72.8 km
R1 = 3.16 ohms
X1 = 21.76 ohms
C1 = 0.9265 microfarads

220kV Duplex HTC from HLE-WKM

Rating 1000/1000 MVA
Length 118.20 km
R1 = 5.13 ohms
X1 = 35.01 ohms
C1 = 1.504 microfarads

220kV Duplex HTC from WKM-HAM

Rating 1000/1000 MVA
Length 91 km
R1 = 3.94 ohms
X1 = 27.19 ohms
C1 = 1.158 microfarads

40% Series Compensation on OTA-WKM A&B Lines with HTC

Rating : 2.62 KA
Capacitive reactance : 23.684 ohms
Reactive power at full current : 488 Mvar

25% Series Compensation on HLE-OTA circuits with HTC

Rating : 2.62 KA
Capacitive reactance : 5.44 ohms
Reactive power at full current : 112 Mvar

30% Series Compensation on HAM-WKM circuit with HTC

Rating : 2.62 KA
Capacitive reactance : 8.157 ohms
Reactive power at full current : 168 Mvar

30% Series Compensation on WKM-ORM circuits

Rating : 3.246 KA
Capacitive reactance : 15.24 ohms
Reactive power at full current : 482 Mvar

Appendix C Upper North Island Demand Forecast Data

Year	Prudent Demand Growth		
	Winter	Summer	High Summer
2010	2,440	2,237	1,856
2011	2,525	2,315	1,921
2012	2,630	2,410	2,000
2013	2,704	2,479	2,057
2014	2,778	2,546	2,113
2015	2,878	2,638	2,189
2016	2,963	2,716	2,254
2017	3,057	2,802	2,326
2018	3,136	2,875	2,386
2019	3,235	2,965	2,461
2020	3,301	3,026	2,511
2021	3,402	3,118	2,587
2022	3,491	3,200	2,655
2023	3,605	3,304	2,742
2024	3,674	3,368	2,795
2025	3,754	3,441	2,855
2026	3,850	3,529	2,929
2027	3,930	3,602	2,989
2028	3,999	3,666	3,042
2029	4,104	3,762	3,122
2030	4,186	3,837	3,184
2031	4,279	3,922	3,255
2032	4,370	4,005	3,324
2033	4,483	4,109	3,410
2034	4,579	4,197	3,483
2035	4,669	4,279	3,551
2036	4,760	4,363	3,621
2037	4,854	4,449	3,692
2038	4,968	4,554	3,779
2039	5,066	4,644	3,853
2040	5,182	4,750	3,941
2041	5,335	4,890	4,058
2042	5,423	4,970	4,125
2043	5,535	5,073	4,210
2044	5,660	5,188	4,305

Appendix D Environmental and Property Risks

Environmental risks

Transmission lines are designed to ensure that the ICNIRP guideline electric field strength level is not exceeded at the point of highest field level (generally the bottom of a sagging conductor). This also prevents the magnetic field strength from being exceeded. Field strengths fall away in at least inverse proportion to the distance from the conductor, and in some cases more rapidly.

Transpower has adopted the ICNIRP Guidelines in designing transmission lines. These have influenced the design of 220kV and 400kV alternatives, particularly the height of the overhead conductors. In general, when determining the position of the conductors with respect to the ground and adjacent activities, the limiting factors are the electric field strength and the potential for noise from corona discharge. If the guidelines and standards relating to electric field and noise conditions are met, (as they are designed to be), the magnetic field strengths will be well below reference levels.

Transpower now purchases easements for new lines as an additional safeguard, to ensure that there are no dwellings or other substantial buildings where people may spend long periods of time within the designated area.

Transpower expects the current standards to be relatively stable in the long term. The National Radiation Laboratory, the Government's advisor on ELF EMF, in its evidence to Fern wood Dairies case addresses the suggestion of tightened standards in some countries (refer s7.6 to s7.28 of NRL's evidence) stating there would seem to be very little risk of arbitrary lower standards in NZ.

On the worldwide front, there is no indication that either ICNIRP or World Health Organisation is likely to tighten the standards that are currently provided.

Transpower keeps abreast of developments in both the research and regulation as applied to ELF EMF. Transpower sits on the Government's "Interagency Advisory Committee on Health Effects of Non-Ionising Fields". As such, Transpower is well informed of developments in NZ and overseas and is in a position to ensure the consequences on power system operation of amending ELF EMF limits are known in the policy debate.

In the current review of the need for a national Environmental Standard on ELF EMF for transmission, there is no suggestion of a move away from ICNIRP as a basis for such a standard.

All alternatives presently being considered have electric field levels close to the present ICNIRP everyday recommended level. So all proposals are equally exposed to changes in ICNIRP limits. However new lines have an advantage over reuse of existing towers as an easement is purchased limiting building under the lines, and an allowance for some margin over existing ICNIRP limits can be made usually at a smaller cost than for existing lines.

It is Transpower's opinion, that, a new build 400kV option has an advantage over the other options for the following reasons:-

- for a given power flow, magnetic fields would be lower, with a higher voltage line, which is an advantage of a new 400kV over a new build 220kV option
- the area and properties influenced by ELF EMF under a single 400kV line will be smaller than multiple lines under lower voltage options which is an advantage of a new 400kV over a new build 220kV option which will require more lines than a 400kV option.
- electric field compliance is not threatened by the presence of under building, which is an advantage that a 220kV or a 400kV option have over reuse of existing assets.
- with a new line, Transpower's design meets ICNIRP beneath the conductors. Other countries eg UK, comply only at the easement boundary or at the closest dwellings, which is an advantage that a 220kV or a 400kV option have over reuse of existing assets

Property Costs

It has been suggested that Simplex High Temperature Conductor (HTC) could be used in places where the replacement of the existing Goat conductor with duplex Goat conductor triggers property costs.

However, using simplex HTC may trigger injurious affection and hence the need for property rights. In particular, while there is no significant visual impact, the EMF levels increase significantly (as shown in Figures D-1 and D-2) and while less than those under duplex Goat and well less than the ICNIRP limits, this increase in itself may be an issue in more densely populated parts of the route.

Installing HTC on to the OTA-WHAK A & B line, using the rights contained under section 23(3)(b) of the Electricity Act will at the very least challenge those right substantially. Even if Transpower decides to take a chance and proceed with the works, landowners will exercise their rights and deny access to their properties, initiate section 23F (Electricity Act) action and challenge our rights through the Environment Court, thus creating significant delays to the works.

Transpower has recently been publicly challenged on thermal upgrading projects by numerous individuals supported by clear statements from Federated Farmers both Auckland & Waikato Branches, denying access until Transpower accepts that this type of works including duplexing is outside its statutory rights and new property rights must be obtained and compensation must be paid. Transpower has already received a growing number of written notices from landowners stating their intention of denying access.

It is Transpower's view that a combination of HTC simplex conductors and duplexing conductors using section 23(3)(b) would generate so much challenge and delay in trying to defend its rights that this work would simply be too risky and the project should only proceed on the basis that property rights be obtained from the outset

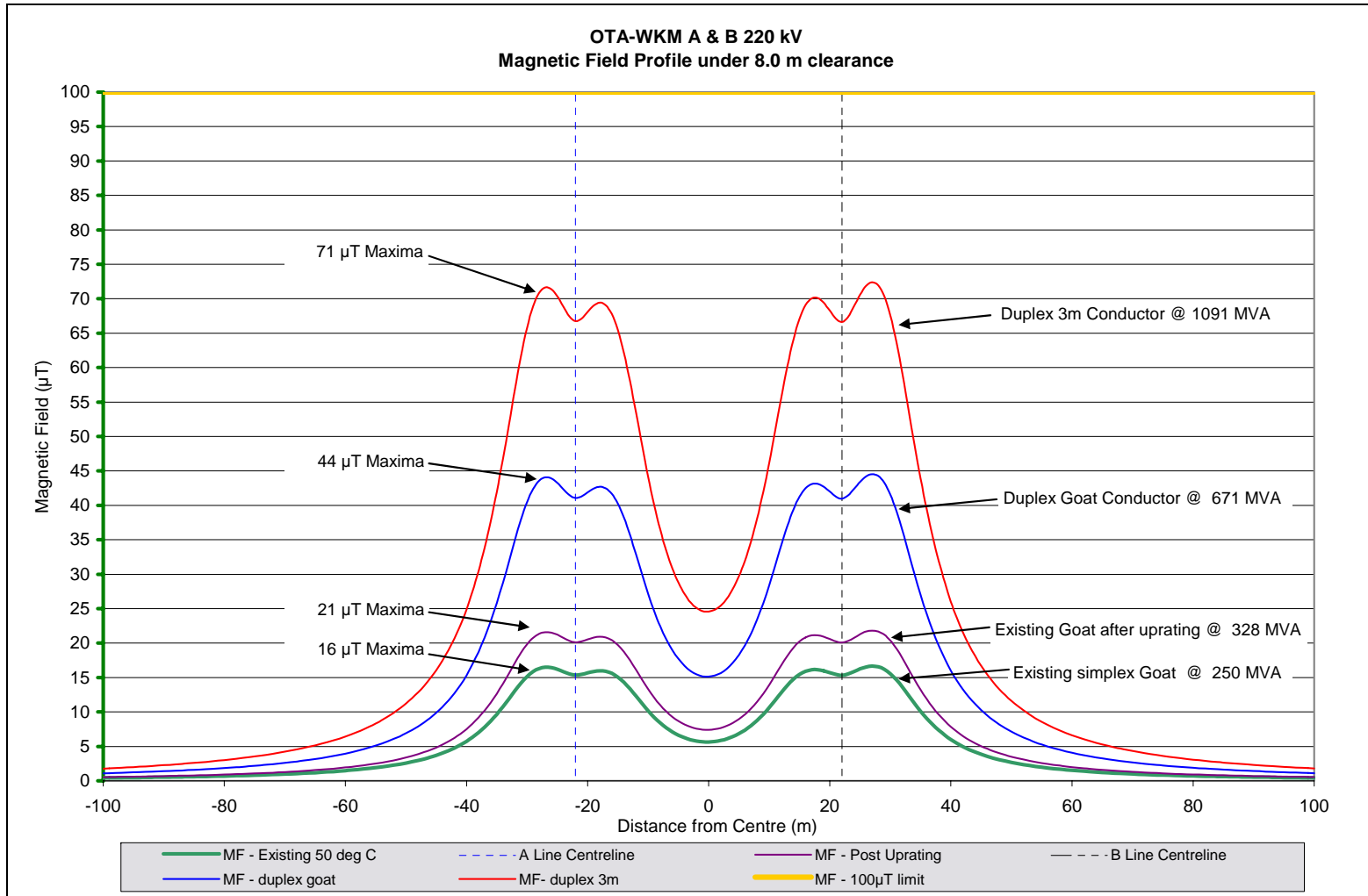

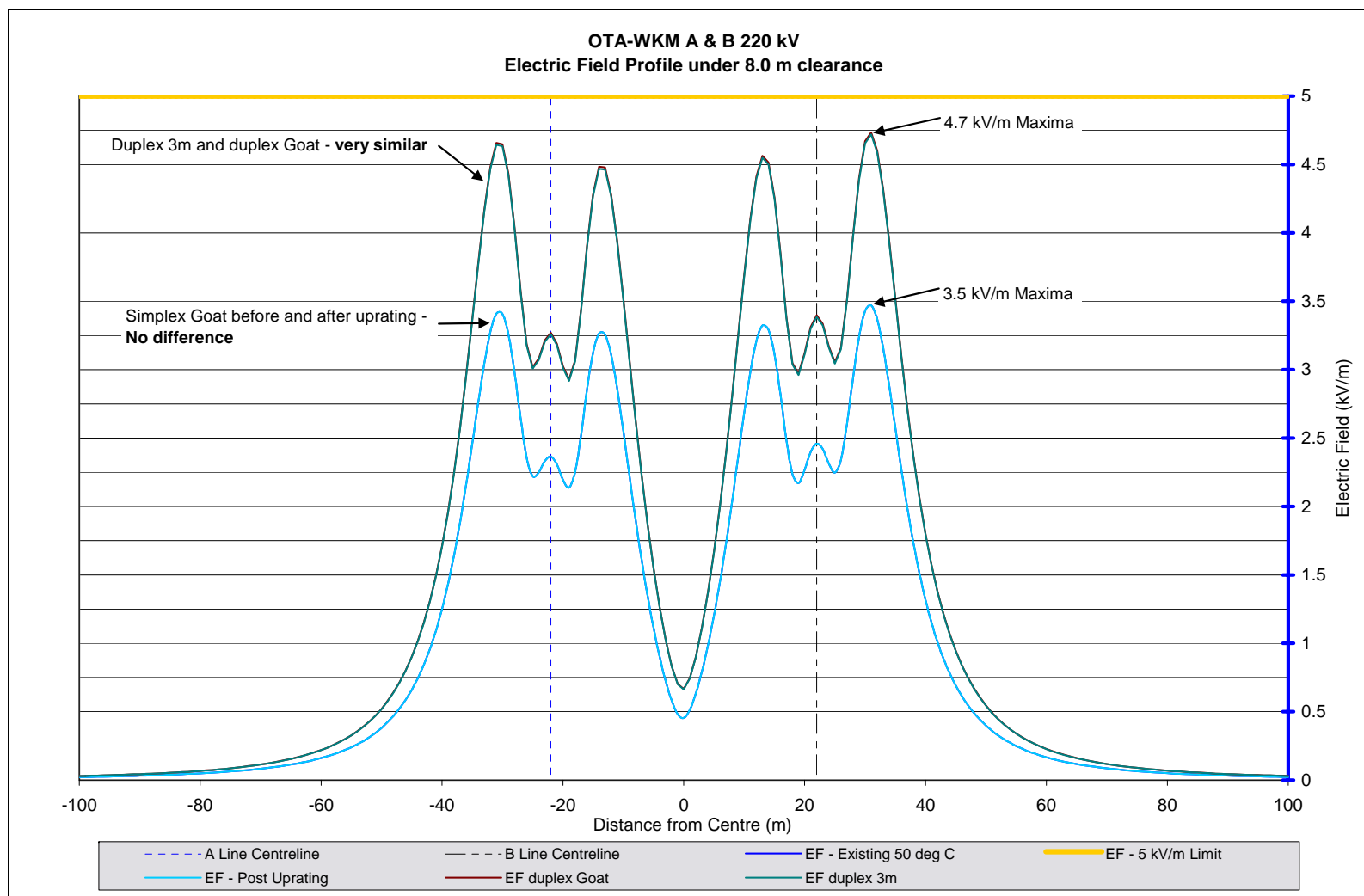

Figure D-2. Electric fields under OTA – WKM A&B lines

Appendix E Data for Graphs and Study Cases

Graphs/Tables	Filename
Transmission Losses <ul style="list-style-type: none"> • Figure 6-10 • Figure F-1 	Losses.xls
Reactive Support requirement at Otahuhu and Huntly (Figure 6-11)	Reactive Plans.xls
Dynamic reactive power Requirement <ul style="list-style-type: none"> • Figure 6-12 • Figure 6-13 • Figure 6-14 • Figure 6-15 	DynamicRequirementCharts.xls
Transfer Limits <ul style="list-style-type: none"> • Figure 6-1 • Figure 6-3 • Figure 6-5 • Figure 6-7 • Figure 6-9 • Figure E-7-2 • Figure E-7-4 • Figure E-7-6 • Figure E-7-8 • Figure E-7-10 • Figure E-7-12 	TransferLimits.xls

Appendix F Other Transmission Options Considered

Overview of the Transmission Options

The transmission options assessed in the first phase of the analysis encompassed a number of 220 and 400 kV transmission solutions for ensuring supply reliability to the UNI region as well as providing adequate diversity of the supply to the region. Four options were selected for further detailed analysis and are described in Section 6 of this report.

This appendix describes the remaining transmission development options considered during the initial phase of analysis.

Note: These plans were developed assuming 400 kV was strung with triplex Zebra conductors. This has changed in the detailed plans to triplex Sulphur as this reduced the transmission losses.

Transmission Development Plans

Option 5: A new 400 kV transmission line between Whakamaru and Otahuhu, initially operated at 220 kV. This is a modified version of the 400 kV grid upgrade plan submitted to the Electricity Commission in September 2005 which defers construction of the 400 kV substations by initially operating the 400 kV transmission line at 220 kV. There are two sub-options for upgrading the transmission line to 400 kV operation when the 220 kV capacity runs out, as follows:

Option 5.1: early conversion to 400 kV:

- construct new 400 kV substations at Otahuhu and Whakamaru and upgrade the line to 400 kV operation, by constructing new 400 kV substations at Otahuhu and Whakamaru
- install series capacitors on the 400 kV transmission line to increase power transfer into Auckland, as required.

Option 5.2: defer conversion to 400 kV:

- install series capacitors on the 220 kV transmission lines to increase power transfer into Auckland and defer conversion of the new transmission line from 220 kV operation to 400 kV operation
- when the additional capacity of the series compensated line runs out, upgrade the line to operate at 400 kV, by constructing new 400 kV substations at Otahuhu and Whakamaru

Option 5.1 – 400 kV into Otahuhu (early conversion to 400 kV)

This option considers the 400 kV investment, without augmenting the existing network, apart from those identified as common augmentations listed in Section 5.1.

The 400 kV transmission line will be commissioned and initially operated at 220 kV in 2012. This would increase the transfer limit to the UNI to approximately 3,500 MW.

In 2022, the new line will be upgraded to operate at 400 kV, by building 400 kV sub stations at Otahuhu and Whakamaru. This increases the UNI transfer limit to approximately 4,800 MW.

By 2035, there is a overloading on Hamilton-Whakamaru 220 kV circuit, when a 400 kV circuit is out of service. At the same time the Otahuhu-Whakamaru A&B circuits are also close to their load limits. As there is still a substantial capacity left on the 400 kV line, it is proposed to install series capacitors on the 400 kV overhead lines up to 50%¹⁸. The series capacitors significantly increase the power sharing by the 400 kV line and thus increases the transfer limit to approximately 5,050 MW.

Re-conductoring of the Otahuhu and Whakamaru A& B lines to twin goat at 80 degrees increases the transfer limit above 5,500 MW.

The Thermal and the Reactive development plans for Option 5.1 is shown in Table E-1 and Table E-2 and pictorially in Figure E-7-1.

Option 5.1: 400kV to Otahuhu (early conversion to 400 kV)				
Transfer Limit (MW)	Year	Augmentation	Type of Project	Reason
2572	2010	Decommission 110 kV ARI-PAK line	GIT	New line uses this line route
3356	2011	Commission 2x400 kV circuits (triplex Zebra) operated at 220 kV from WKM to ORM	GIT	HAM-WKM overloads in HLE-WKM outage
		Commission 2x400 kV cables operated at 220 kV from OTA to ORM	GIT	
		Cable Transition Station at ORM	GIT	
3386	2012	Commission 1x220 kV cable from PEN-OTA	GIT	OTA-PEN 5 & 6 Circuits overloads (due to installation of 1st Cross Harbour Cable)
3482	2013	Reconductor ARI-HAM 1 & 2 to Nitrogen 75°C conductors.	Common	110kV ARI-HAM-2 overloads when ARI-HAM-1 is out (in Summer peak demand).
	2016	Commission 2nd 220 kV PEN-OTA cable	GIT	OTA-PEN o/h overloads in OTA-PEN cable outage
3500	2019	Commission 220 kV Sub station at Pakuranga	Modelled	PEN-OTA cable overloads in PEN-OTA outage
		Install 3x120 MVA supply transformers at PAK	Modelled	
		Commission 1x220 kV PAK-PEN cable	Modelled	

¹⁸ No attempt is made to optimise the level of compensation, 50% is chosen as a typical value. The actual value will be confirmed for the preferred option.

Option 5.1: 400kV to Otahuhu (early conversion to 400 kV)				
Transfer Limit (MW)	Year	Augmentation	Type of Project	Reason
		Convert existing OTA-PAK circuits to 220 kV	Modelled	
4027	2021	Commission 1x110 kV OTA-WIR cable, close WIR bus breaker	Common	OTA-WIR overloads in BOB-WIR outage
		400 kV Sub station at Otahuhu	Modelled	HAM-WKM overloads in ORM-WKM outage
		400 kV Sub station at Whakamaru	Modelled	
		3x400/220 kV ICTs at WKM	Modelled	
		3x400/220 kV ICTs at OTA	Modelled	
4150	2023	4th 400/220 kV ICT at WKM	Modelled	WKM 400/220 kV overloads in WKM 400/220 kV outage
		4th 400/220 kV ICT at OTA	Modelled	OTA 400/220 kV overloads in OTA 400/220 kV outage; having this transformer defers the need for additional cable from ORM-PAK by 6 years
	2024	2nd ROS ICT	Common	ROS ICT overloads pre contingency
	2026	Re-conductor HAM-BOB 110 kV circuits to Nitrogen Conductors.	Common	Overload on circuits in contingency in 2027 (Summer High).
	2027	2nd PEN-ROS cable	Common	OTA T5 and HEP-HEN overloads in PEN-ROS outage
4470	2028	2nd PAK-PEN cable	Modelled	PEN-OTA overloads in PEN-OTA outage
		Thermal upgrade of HLE-WKM to twin goat at 80 deg	Modelled	HAM-WKM overloads in 400 kV circuit outage
4555	2030	Install 25 ohm reactors on OTA-WKM A&B circuits	Modelled	OTA-WKM A&B overload in 400 kV circuit outage
		400 kV Switching station at Ormiston Rd	Modelled	ORM-OTA overloads in 400 kV circuit outage
		400 kV sub station at Pakuranga	Modelled	
		Install 1x400/220 kV ICT at Pakuranga	Modelled	
		Decommission 4th 400/220kV, 500MVA Transformer at OTA, Use as spare and move the spare at Otahuhu to Pakuranga	Modelled	

Option 5.1: 400kV to Otahuhu (early conversion to 400 kV)				
Transfer Limit (MW)	Year	Augmentation	Type of Project	Reason
		Commission 1x400 kV cable from ORM-PAK	Modelled	
5096	2032	3rd ROS ICT	Common	ROS ICT overloads in ROS ICT outage
		2nd PAK400/220 kV ICT	Modelled	PAK ICT overloads in OTA ICT outage
		5th WKM 400/220 kV ICT	Modelled	WKM 400/220 kV ICT
		2nd 400 ORM-PAK 400 kV cable	Modelled	ORM-OTA overloads in ORM-OTA outage
5125	2035	Install 2x50% compensation on ORM-WKM circuits	Modelled	HAM-WKM, ARI-BOB overload in ORM-WKM
		3rd PAK 400/220 kV ICT	Modelled	PAK 400/220 kV overloads in PAK 400/220 kV outage
		6th WKM 400/220 kV ICT	Modelled	WKM 400/220 kV overloads in WKM 400/220 kV outage
	2037	1X75 MVA PST on ARI-BOB 110 kV Circuit	Modelled	Reduce overload in summer
		New OTA 220/110 kV ICT in parallel with T3 and T5	Common	OTA T5 overloads in OTAT3 outage
5406	2039	Duplex OTA-WKM A&B, remove series reactors	Modelled	ORM-WKM overloads in ORM-WKM outage
5561	2040	Reduce compensation on ORM-WKM circuits to 40%	Modelled	ORM-WKM overloads in ORM-WKM outage
5617	2041	3rd ORM-OTA cable	Modelled	ORM-OTA overloads in ORM-OTA outage

Table E-1: Thermal Development Plan for Option 5.1

Reactive Plan : Option 5.1 (400 kV to OTA, early conversion to 400 kV))

Year	Location	Quantity (MVAR)	Static/Dynamic*
2008	OTA	250	S
2009	OTA	100	S
2017	OTA	200	D
2019	HLY	100	S
2026	OTA	150	S
2029	HLY	100	S
2033	OTA	200	D
2033	HLY	100	S
2035	OTA	150	S
2039	OTA	350	S
2042	OTA	350	S
Total		2050	

* Dynamic requirement for transmission contingency into Auckland ONLY

Table E-2: Reactive Plan for Option 5.1

NORTH ISLAND GRID UPGRADE PROJECT – AMENDED PROPOSAL
ATTACHMENT D – TECHNICAL ASSESSMENT OF MODIFIED OPTIONS

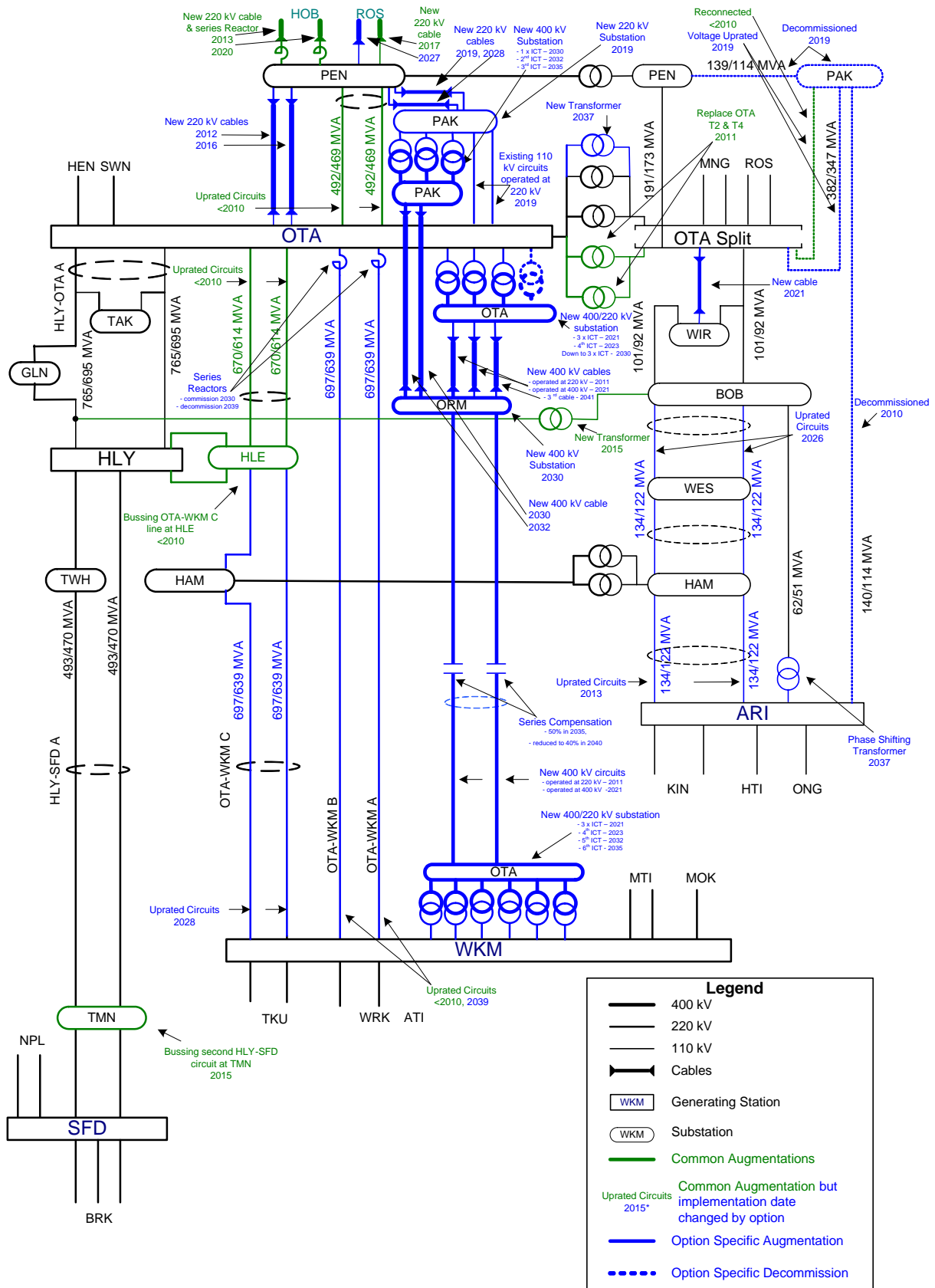

Figure E-7-1: Option 5.1

The transfer limit for this option is shown in Figure E-7-2.



Figure E-7-2: Increase in transfer limit to UNI under Option 5.1

Option 5.2 – 400 kV into Otahuhu (defer conversion to 400 kV)

This option considers the 400 kV investment, without augmenting the existing network apart from those identified as common augmentations listed in Section 5.1.

The difference with option 5.1 is that rather than upgrading to 400 kV operation, the lines operating at 220 kV will be series compensated first.

The 400 kV transmission line will be commissioned and initially be operated at 220 kV in 2012 increasing the transfer limit to the UNI to approximately 3,500 MW.

In 2022, the new line (operated at 220 kV) is 50% series compensated, which increases the transfer limit to approximately 4,400 MW.

By 2031, the line needs to be upgraded to 400 kV operation, by commissioning new 400 kV sub-stations at Otahuhu and Whakamaru. With this development, the network capability is the same as that in option 5.1.

The Thermal and the Reactive development plans for Option 5.2 are shown in Table E-3 and Table E-4 and pictorially in Figure E-7-3.

Option 5.2: 400kV to Otahuhu (deferred conversion to 400 kV)				
Transfer Limit (MW)	Year	Augmentation	Type of Project	Type of Project
2571	2010	Decommission 110 kV Ari-Pak line	GIT	New line uses this line route
3356	2011	Commission 2x400 kV ccts operated at 220 kV from WKM to ORM	GIT	HAM-WKM overloads in HLE-WKM outage
		Commission 2x400 kV cables operated at 220 kV from OTA to ORM	GIT	HAM-WKM overloads in HLE-WKM outage
		Cable Transition Station at ORM	GIT	
3386	2012	Commission 1x220 kV cable from PEN-OTA	GIT	OTA-PEN 5 & 6 Circuits overloads (due to installation of 1st Cross Harbour Cable)
3482	2013	Reconductor ARI-HAM with Nitrogen 75 deg C Conductor	Common	ARI-HAM 2 overloads in ARI-HAM 1 outage
	2016	Commission 2nd 220 kV PEN-OTA cable	GIT	OTA-PEN o/h overloads in OTA_PEN cable outage
3500	2019	Commission 220 kV bus at Pakuranga	Modelled	PEN-OTA cable overloads in PEN-OTA outage
		Install 3x120 MVA supply transformers at PAK	Modelled	
		Commission 1x220 kV PAK-PEN cable	Modelled	
		Convert existing OTA-PAK circuits to 220 kV	Modelled	
3879	2021	Commission 1x110 kV OTA-WIR cable, close WIR bus breaker	Common	OTA-WIR overloads in BOB-WIR outage

Option 5.2: 400kV to Otahuhu (deferred conversion to 400 kV)				
Transfer Limit (MW)	Year	Augmentation	Type of Project	Type of Project
		Install 50% compensation on ORM-WKM circuit	Modelled	HAM-WKM overloads in ORM-WKM outage
		Commission 1x400kV ORM-PAK cable	Modelled	ORM-OTA overloads in OTA-WKM outage
		Commission switching station at Ormiston Rd	Modelled	ORM-OTA overloads in OTA-WKM outage
3941	2024	2nd ROS ICT	Common	ROS ICT overloads in OTA ICT outage
4029	2026	Thermal Upgrade of HLE-WKM section of OTA-WKM C line	Modelled	HAM-WKM overloads in ORM-WKM outage
		2nd ORM-PAK cable	Modelled	ORM-OTA overloads in ORM-OTA
		Re-conductor HAM-BOB 110 kV circuits to Nitrogen Conductors.	Common	Overload on circuits in contingency in 2027 (Summer High).
	2027	Install 25 ohm series reactors on the OTA-WKM A&B circuits	Modelled	OTA-WKM A&B overload in ORM-WKM outage
		2nd PEN-ROS cable	Common	OTA ICT and HEN-HEP overload in PEN-ROS outage
5203	2031	400 kV sub-station at Whakamaru	Modelled	HAM-WKM overload in ORM-WKM outage
		400 kV sub-station at Otahuhu	Modelled	
		400 kV sub-station at Pakuranga	Modelled	
		Install 5x400/220 kV ICTs at Whakamaru	Modelled	
		Install 3x400/220 kV ICTs at Otahuhu	Modelled	
		Install 2x400/220 kV ICTs at Pakuranga	Modelled	
	2032	2nd PAK-PEN cable	Modelled	Pen-OTA overloads in PEN-OTA outage

Option 5.2: 400kV to Otahuhu (deferred conversion to 400 kV)				
Transfer Limit (MW)	Year	Augmentation	Type of Project	Type of Project
		3rd ROS 220/110 kV ICT	Common	OTA T3 overloads in OTA T3 ROS ICT overloads in ROS iCT outage
	2033	3rd PAK 400/220 kV ICT	Modelled	PAK 400/220 kV ICT overloads in PAK 400/220 kV ICT outage
	2034	6th WKM 400/220 kV ICT	Modelled	WKM 400/220 kV ICT overloads in WKM 400/220 kV ICT outage
	2037	1X75 MVA PST on ARI-BOB 110 kV Circuit	Modelled	Reduce overload in summer
		New OTA 220/110 kV ICT in parallel with T3 and T5	Common	OTA T5 overloads in OTAT3 outage
5522	2039	Duplex OTA-WKM A&B, remove series reactors	Modelled	ORM-WKM overloads in ORM-WKM outage
5564	2040	Reduce compensation on ORM-WKM circuits to 40%	Modelled	ORM-WKM overloads in ORM-WKM outage
5750	2041	3rd ORM-OTA cable	Modelled	ORM-OTA overloads in ORM-OTA outage

Table E-3: Thermal Development Plan for Option 5.2

Reactive Plan : Option 5.2 (400 kV to OTA, deferred conversion to 400 kV))

Year	Location	Quantity (MVAR)	Static/Dynamic*
2008	OTA	250	S
2009	OTA	100	S
2017	OTA	200	D
2019	HLY	100	S
2022	OTA	200	S
2026	OTA	150	S
2028	OTA	250	S
2029	HLY	100	S
2032	OTA	200	D
2033	HLY	100	S
2039	OTA	50	S
2042	OTA	350	S
Total		2050	

* Dynamic requirement for transmission contingency into Auckland ONLY

Table E-4: Reactive Plan for Option 5.2

The transfer limit for this option is shown in Figure E-7-4:



Figure E-7-4: Transfer Limits against forecast demand for Option 5.2

Option 6 – 220 kV into Otahuhu

This option considers a new high capacity 220 kV transmission line between Whakamaru and Otahuhu, compensated with series capacitors, when required. Additional 220 kV circuits are added between Whakamaru and Pakuranga, when required.

This option considers the 220 kV investment, without augmenting the existing network apart from those identified as common augmentations listed in Section 5.1.

This option considers building transmission lines into Auckland at 220 kV instead of 400kV. To make reasonable comparisons with the 400 kV options, large conductors (twin chukar) were considered for the new lines. This option also considers installing series capacitors on the 220 kV lines, when needed.

As with options 5.1 and 5.2, the new line is needed in 2012. This increases the transfer limit to approximately 3,500 MW.

In 2022, this line is series compensated by 50% to increase the transfer limits to approximately 3,900 MW.

By 2026, the Otahuhu-Whakamaru A&B circuits are constraining, and therefore series reactors are commissioned to reduce the overloading on these circuits. This and other augmentations increase the transfer limit to approximately 4,400 MW.

In 2031, a second 220 kV double circuit transmission line is required, which increases the transfer capacity above 6,000 MW.

The Thermal and the Reactive development plans for Option 6 are shown in Table E-5 and Table E-6 and pictorially in Figure E-7-5.

Option 6: 220kV to Otahuhu				
Transfer Limit (MW)	Year	Augmentation	Type of Project	Reason
2571	2010	Decommission 110 kV Ari-Pak line	GIT	New line uses this line route
3327	2011	2x220 kV, twin chukar circuits from WKM to ORM	GIT	HLE-OTA 2 circuit overloads on HLE-OTA 1 outage
		2x220 kV, 2500 mm ² cables from ORM to OTA	GIT	
	2012	1x220 kV cable from PEN-OTA	GIT	Overloads on OTA-PEN 5/6 under OTA-PEN 5/6 contingencies
3441	2013	Reconductor ARI-HAM with Nitrogen 75 deg C Conductor	Common	110 kV ARI-HAM-2 overloads for ARI-HAM-1 contingency (Summer Hi)
3526	2016	2nd 220 kV PEN-OTA cable	GIT	OTA-PEN cable overload under OTA-PEN 6 contingency
3588	2019	Create 220kV sub station at PAK	Modelled	OTA-ORM cables run out of capacity. Diverse transmission path through PAK created.
		Install 3x120 MVA supply transformers at PAK	Modelled	
		Shift PAK 110 kV load to 220 kV	Modelled	
		1x220 kV, 2500 mm ² cables from PAK to PEN	Modelled	
		Shift existing OTA-PAK 110 kV circuits to operate 220 kV	Modelled	
3989	2021	110 kV OTA-WIR cable; close the WIR bus breaker	Common	OTA-WIR overloads in BOB-WIR-OTA outage
		50% Series Compensation on the 2 x WKM-ORM 220 kV lines	Modelled	HAM-HLY and OTA-WKM A&A overloads in WKM-ORM-OTA contingency
		Create ORM Switching station	Modelled	
		Install 1st ORM-PAK 220 kV cable	Modelled	

Option 6: 220kV to Otahuhu				
Transfer Limit (MW)	Year	Augmentation	Type of Project	Reason
4053	2024	2nd ROS Interconnector	Common	ROS Interconnector overloads in 2026 when OTA T5 is out.
		Upgrade HLE-WKM section of OTA-WKM C to Twin Goat 80 deg C	Modelled	HAM-WKM overloads in WKM-ORM contingency
	2026	15 ohm Series reactors on the OTA-WKM A&B lines	Modelled	OTA-WKM A&B overloads in WKM-ORM contingency
		Re-conductor 110 kV HAM-BOB circuits to Nitrogen Conductors.	Common	Overload on circuits in contingency in 2027 (Summer High).
	2027	2nd PEN-ROS Cable	Common	Overloads on OTA T5 when PEN-ROS Cable is out in 2028.
4390	2028	2nd ORM-PAK cable	Modelled	Increase cable capacity
4701	2031	2x220 kV, twin Chukar circuits from WKM to ORM	Modelled	WKM-ORM-OTA overloads in WKM-ORM contingency
		3rd 220 kV OTA-ORM cable	Modelled	
5118	2032	3rd ROS Interconnector	Common	Overload on ROS Interconnector when ROS T1 is out in 2033.
		2nd PEN-PAK cable	Modelled	OTA-PEN Cable overloads for PEN-PAK cable outage
	2036	1X75 MVA PST on ARI-BOB 110 kV Circuit	Common	Reduce overload
	2037	New OTA 220/110 kV Interconnector to be installed (similar to T5)	Common	Overload on OTA T5 for a contingency on OTA T3.
5437	2039	3rd ORM-PAK cable	Modelled	Cable overloads for ORM-PAK cable outage
5750	2040	50% Series compensate on 2nd WKM-ORM 220 kV circuits	Modelled	Overloads on OTA-WKM A&B lines under WKM-ORM contingency

Table E-5: Thermal Development Plan for Option 6

Reactive Plan : Option 6 (220 kV to Otahuhu)

Year	Location	Quantity (MVAR)	Static/Dynamic*
2008	OTA	250	S
2009	OTA	100	S
2019	OTA	100	D
2019	HLY	100	S
2022	OTA	100	S
2023	OTA	100	S
2025	OTA	150	S
2027	OTA	100	D
2027	HLY	100	S
2029	OTA	200	S
2029	HLY	100	S
2035	OTA	200	S
2038	OTA	200	S
2039	OTA	100	S
2042	OTA	350	
Total		2250	

* Dynamic requirement for transmission contingency into Auckland ONLY

Table E-6: Reactive Plan for Option 6

The transfer limit for this option is shown in Figure E-7-6:

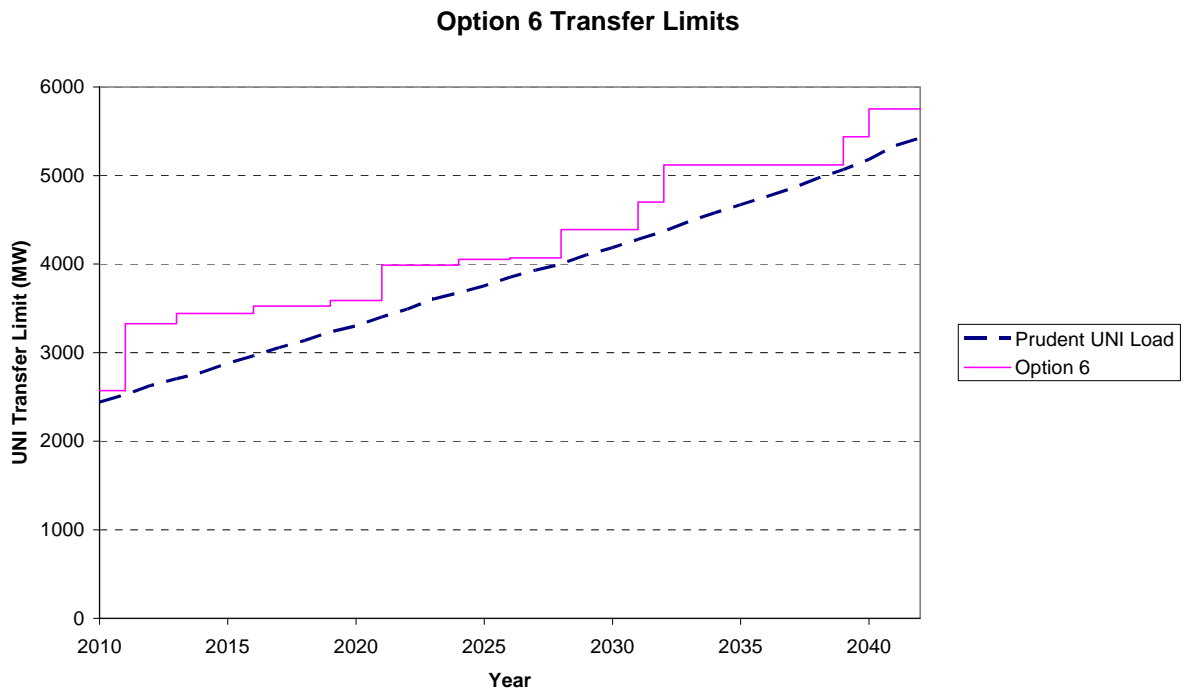

Figure E-7-6: Transfer Limits against forecast demand for Option 6

Option 7: 400 kV into Pakuranga and Otahuhu

Option 7.1: building a 400 kV double circuit overhead line between Whakamaru and Ormiston Road. Initially the 400 kV transmission lines will be connected to Pakuranga using 400 kV underground cables (from Ormiston Road to Pakuranga). Subsequently, additional 400 kV cables will be used to transmit power from Ormiston Road to Otahuhu. The transmission circuits will initially be operated at 220 kV and converted to operate at 400 kV when required. The high capacity 400 kV circuits are then series compensated to increase the transfer capacity into the Upper North island.

Option 7.2: building a 400 kV double circuit overhead line between Whakamaru and Ormiston Road. Initially the 400 kV transmission lines will be connected to Pakuranga using 400 kV underground cables (from Ormiston Road to Pakuranga). Subsequently, additional 400 kV cables will be used to transmit power from the Ormiston Road to Otahuhu. The transmission circuits will initially be operated at 220 kV and series compensated to increase the transfer capacity to UNI as long as possible. When the transfer capacity is exhausted, the transmission circuits are converted to operate at 400 kV and new 400/220 kV interconnections will be installed at Pakuranga and Otahuhu to increase the transfer capacity into the Upper North Island.

Option 7.1: 400 kV into Pakuranga and Otahuhu (early conversion to 400 kV)

This option considers the 400 kV investment, without augmenting the existing network, apart from those identified as common augmentations listed in Section 5.1.

The 400 kV transmission line will be commissioned and initially operated at 220 kV in 2012. This would increase the transfer limit to the UNI to approximately 3,500 MW.

In 2022, the new line will be upgraded to operate at 400 kV, by building 400 kV sub stations at Otahuhu and Whakamaru. This increases the UNI transfer limit to approximately 4,300 MW.

With other augmentations, including current limiting reactors on Otahuhu-Whakamaru A&B circuits, the transfer limit is increased to approximately 4,800 MW.

By 2035, there is a overloading on Hamilton-Whakamaru 220 kV circuit, when a 400 kV circuit is out of service. At the same time the Otahuhu-Whakamaru A&B circuits are also close to their load limits. As there is still a substantial capacity left on the 400 kV line, it is proposed to install series capacitors on the 400 kV overhead lines up to 50%¹⁹. The series capacitors increase the power sharing by the 400 kV line and this increases the transfer limit to approximately 5,000 MW.

Re-conductoring of the Otahuhu and Whakamaru A& B lines to twin goat at 80 degrees, increases the transfer limit above 5,500 MW.

The Thermal and the Reactive development plans for Option 7.1 are shown in Table E-7 and Table E-8 and pictorially in Figure E-7-7.

¹⁹ No attempt is made to optimise the % of compensation, 50% is chosen as a typical value. The actual value will be confirmed for the preferred option.

Option 7.1 : 400kV to Pakuranga(early conversion to 400 kV)				
Transfer [mm] (MW)	Year	Augmentation	Type of Project	Reason
2571	2010	Decommission 110 kV Ari-Pak line	GIT	New line uses this line route
3277	2011	Cable Transition Station at Ormiston Road	GIT	Hle-OTA overloads in HLE-OTA
		Commission 2x400 kV, 3xZebra circuits from WKM to ORM, operate at 220kV	GIT	
		Commission 2x400 kV, cables from PAK to ORM, operate at 220kV	GIT	
		Shift 110kV PAK bus load to 220kV PAK Bus	GIT	
		Install 3x120 MVA supply transformers at PAK	GIT	
		Shifted OTA-PAK 110kV double circuits to 220kV	GIT	
		Commission 1st PEN-PAK 220kV Cable	GIT	Overloading of OTA-PEN 6 line due to OTA-PEN 5 contingency in 2013, but brought forward to create diversity of Power supply
3468	2013	Reconductor ARI-HAM with Nitrogen 75 deg C Conductor	Common	ARI-HAM overloads in ARI-HAM outage
	2016	Commission 2nd PEN-PAK 220kV Cable	GIT	Overloading of OTA-PEN 6 line due PEN-PAK 220kV contingency
	2020	Commission 1st PEN-OTA 220kV Cable	Modelled	Overloading of PEN-PAK 220kV due to PEN-PAK 220kV contingency
4132	2021	400 kV sub-station at Whakamaru		HAM-HLE and OTA-WKM A&B overloads in WKM-ORM-PAK contingency
		400 kV sub station at Pakuranga		
		3 x 500MVA, 400/220kV Transformers each at WKM & PAK	Modelled	
		WKM-ORM-PAK lines operated at 400kV.	Modelled	
		Commission 1x110 kV OTA-WIR cable, close WIR bus breaker	Common	OTA-WIR overloads in BOB-WIR outage
4252	2023	Commission 4th 400/220kV, 500MVA Transformer at WKM	Modelled	Transformer overloads for Transformer contingency
		Commission 4th 400/220kV, 500MVA Transformer at PAK	Modelled	

Option 7.1 : 400kV to Pakuranga(early conversion to 400 kV)				
Transfer [mm] (MW)	Year	Augmentation	Type of Project	Reason
	2026	Re-conductor HAM-BOB 110 kV circuits to Nitrogen Conductors.	Common	Overload on circuits in contingency in 2027 (Summer High).
	2027	2nd PEN-ROS cable	Common	OTA ICT and HEN-HEP overload in PEN-ROS outage
4304	2028	Upgrade HLE-WKM section of OTA-WKM C to Twin Goat 80 deg C	Modelled	Overloading of HAM-HLE line due to 400kV Line contingency
	2029	Commission second 220kV OTA-PEN Cable	Modelled	PEN-PAK 220kV Cable overloads for PEN-PAK cable contingency
4933	2030	Commission 2 x 25 ohms Series Reactors at OTA-WKM A&B Lines	Modelled	400kV Cable overloads for 400kV cable contingency
		400 kV sub station at Otahuhu	Modelled	
		Commission 1st 400/220kV, 500MVA Transformer at OTA	Modelled	
		400 kV Switching station at Ormiston Rd	Modelled	
		Commission 1st 400kV Cable from ORM-OTA	Modelled	
		Decommission 4th 400/220kV, 500MVA Trasformer at PAK, Use as spare and move the spare at Pakuranga to Otahuhu	Modelled	
5224	2032	Commission 5th 400/220kV, 500MVA Transformer at WKM	Modelled	Transformer overloads for Transformer contingency
		Commission 2nd 400/220kV, 500MVA Transformer at OTA	Modelled	
		Commission 2nd 400kV Cable from ORM-OTA	Modelled	
		3rd ROS 220/110 kV ICT	Common	OTA T3 overloads in OTA T3 ROS ICT overloads in ROS ICT outage
5433	2035	Commission 50% Series Compensation on the 2 x WKM - ORM 400kV Line	Modelled	HAM-HLY and OTA-WKM A&B overloads in WKM-ORM-PAK contingency
		Commission 3rd 400/220kV, 500MVA Transformer at OTA	Modelled	400kV Cable between ORM-PAK overloads for 400kV cable contingency
		Commission 6th 400/220kV, 500MVA Transformer at	Modelled	Transformer overloads for Transformer contingency

Option 7.1 : 400kV to Pakuranga(early conversion to 400 kV)				
Transfer [mm] (MW)	Year	Augmentation	Type of Project	Reason
		WKM		
	2036	1X75 MVA PST on ARI-BOB 110 kV Circuit	Modelled	Reduce overload in summer
	2037	New OTA 220/110 kV ICT in parallel with T3 and T5	Common	OTA T5 overloads in OTAT3 outage
5810	2039	Upgrade OTA-WKM A&B to Twin Goat 80 deg C	Modelled	Overloading of OTA-WKM A&B due to 400kV Line contingency
		De-commission 2x25 Series Reactors on OTA-WKM A & B lines	Modelled	
	2040	Reduce series compensation on the 400kV Line to 40%	Modelled	400kV Line overloads in 2042
	2041	3rd ORM-PAK 400 kV cable	Modelled	ORM PAM cable overloads for 400kV ORM PAK contingency

Table E-7: Thermal Development Plan for Option 7.1

Reactive Plan : Option 7.1 (400 kV to PAK, early conversion to 400 kV))

Year	Location	Quantity (MVAR)	Static/Dynamic*
2008	OTA	250	S
2009	OTA	100	S
2019	OTA	200	D
2022	HLY	100	S
2027	OTA	100	S
2028	HLY	100	S
2028	OTA	150	S
2034	OTA	200	D
2038	HLY	100	S
2038	OTA	300	S
2042	OTA	400	S
Total		2000	

* Dynamic requirement for transmission contingency into Auckland ONLY

Table E-8: Reactive Plan for Option 7.1

The transfer limit for this option is shown in Figure E-7-8:

Option 7.1 Transfer Limits

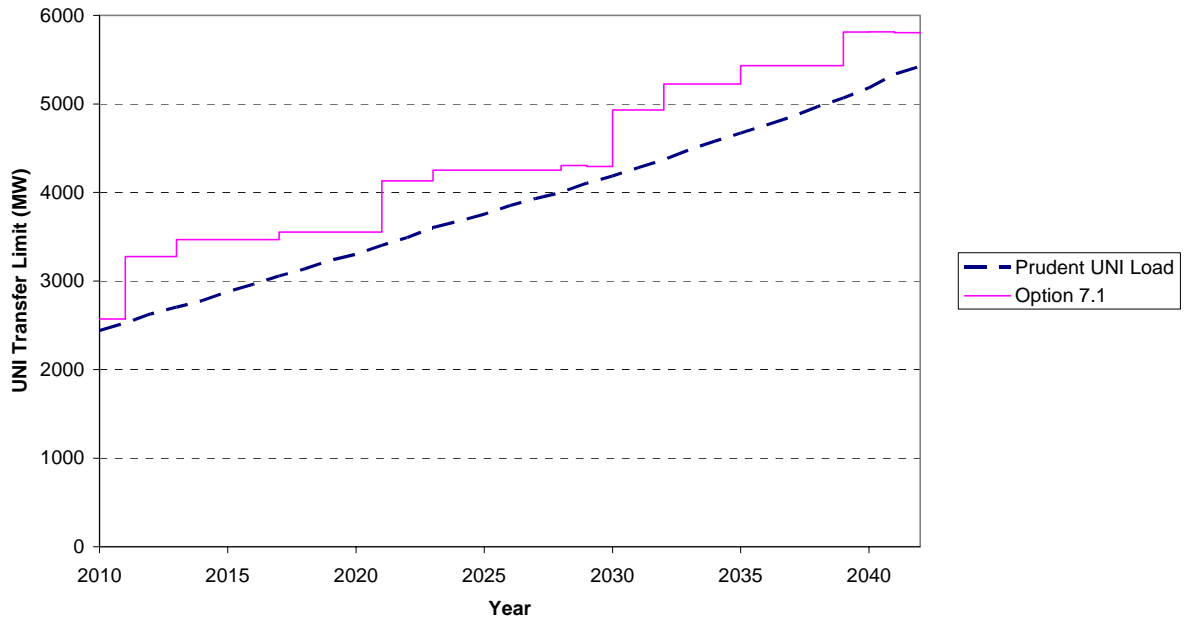

Figure E-7-8: Transfer Limits against forecast demand for Option 7.1

Option 7.2 : 400 kV into Pakuranga and Otahuhu (defer conversion to 400 kV)

This option considers the 400 kV investment, without augmenting the existing network apart from those identified as common augmentations listed in Section 5.1.

The difference with option 7.1 is that rather than upgrading to 400 kV operation, the lines operating at 220 kV will be series compensated first.

The 400 kV transmission line will commissioned and initially be operated at 220 kV in 2012 increasing the transfer limit to the UNI to approximately 3,500 MW.

In 2022, the new line is 50% series compensated, which increases the transfer limit to approximately 4,300 MW.

By 2030, the line needs to be upgraded to 400 kV operation, by commissioning new 400 kV sub-stations at Otahuhu and Whakamaru. With this development, the network capability is the same as that in option 3a.

The Thermal and the Reactive development plans for option 7.1 is shown in Table E-9 and Table E-10 and pictorially in Figure E9.

Option 7.2: 400kV to Pakuranga(deferred conversion to 400 kV)					
Transfer Limit	Year	Augmentation	Type of Project	Reason	
2571	2010	Decommission 110 kV Ari-Pak line	GIT	New line uses this line route	
3277	2011	Cable Transition Station at Ormiston Road	GIT	Hle-OTA overloads in HLE-OTA	
		Commission 2x400 kV, 3xZebra ccts from WKM to ORM, operate at 220kV	GIT		
		Commission 2x400 kV, cables from PAK to ORM, operate at 220kV	GIT		
		Install 3x120 MVA supply transformers at PAK	GIT		
		Shift 110kV PAK bus load to 220kV PAK Bus	GIT		
		Shifted OTA-PAK 110kV double circuits to 220kV	GIT		
		Commission 1st PEN-PAK 220kV Cable	GIT		Overloading of OTA-PEN 6 line due to OTA-PEN 5 contingency in 2013, but brought forward to create diversity of Power supply
3468		2013	Reconductor ARI-HAM with Nitrogen 75 deg C		Common

Option 7.2: 400kV to Pakuranga(deferred conversion to 400 kV)				
Transfer Limit	Year	Augmentation	Type of Project	Reason
		Conductor		
	2016	Commission 2nd PEN-PAK 220kV Cable	GIT	Overloading of OTA-PEN 6 line due PEN-PAK 220kV contingency
	2020	Commission 1st PEN-OTA 220kV Cable	Modelled	Overloading of PEN-PAK 220kV due to PEN-PAK 220kV contingency
3828	2021	Commission 50% Series Compensation on the 2 x WKM - ORM 440kV Line	Modelled	HAM-HLY and OTA-WKM A&B overloads in WKM-ORM-PAK contingency
		Create ORM Switching station	Modelled	
		Commission 1st 400kV cable between ORM -OTA operated at 220kV	Modelled	ORM-PAK 2 overloads on ORM-PAK 1 outage
		Commission 1x110 kV OTA-WIR cable, close WIR bus breaker	Common	OTA-WIR overloads in BOB-WIR outage
	2024	Upgrade HLE-WKM section of OTA-WKM C to Twin Goat 80 deg C	Modelled	Overloading of HAM-HLE line due to 400kV Line contingency
		2nd ROS ICT	Common	ROS ICT overloads in OTA ICT outage
4022	2026	2nd 400kV Cable between ORM-OTA	Modelled	400kV ORM-OTA cable overloads for 400kV PAK-ORM cable contingency
		Re-conductor HAM-BOB 110 kV circuits to Nitrogen Conductors.	Common	Overload on circuits in contingency in 2027 (Summer High).
4407	2027	Commission 2 x 25 ohms Series Reactors at OTA-WKM A&B Lines,	Modelled	OTA-WKM A & B lines overload for 400kv Line contingency
		2nd PEN-ROS cable	Common	OTA ICT and HEN-HEP overload in PEN-ROS outage
	2028			
4489	2031	400 kV Sub station at Whakamaru	Modelled	400kV Line overloads for 400kV line contingency
		400 kV sub station at Pakuranga	Modelled	
		400 kV sub station at Otahuhu	Modelled	
		Commission 5x400/220kV, 500MVA Transformer at WKM	Modelled	
		Commission 3x400/220kV, 500MVA Transformer at PAK	Modelled	

Option 7.2: 400kV to Pakuranga(deferred conversion to 400 kV)				
Transfer Limit	Year	Augmentation	Type of Project	Reason
		Commission 2x400/220kV, 500MVA Transformer at OTA	Modelled	
5197	2032	3rd ROS 220/110 kV ICT	Common	OTA T3 overloads in OTA T3 ROS ICT overloads in ROS ICT outage
5287	2034	Commission 2nd, 220kV OTA-PEN Cable	Modelled	PEN-PAK 220kV Cable overloads for PEN-PAK contingency
		Commission 3rd 400/220kV, 500MVA Transformer at OTA	Modelled	400kV Cable between ORM-PAK overloads for 400kV cable contingency
		Commission 6th 400/220kV, 500MVA Transformer at WKM400	Modelled	Transformer overloads for Transformer contingency
	2036	1X75 MVA PST on ARI-BOB 110 kV Circuit	Modelled	Reduce overload in summer
	2037	New OTA 220/110 kV ICT in parallel with T3 and T5	Common	OTA T5 overloads in OTAT3 outage
5810	2039	Upgrade OTA-WKM A&B to Twin Goat 80 deg C	Modelled	Overloading of OTA-WKM A&B due to 400kV Line contingency
		Decommission 2x25 Series Reactors on A & B lines	Modelled	HAM-HLY and OTA-WKM A&B overloads in WKM-ORM-PAK contingency
	2040	Reduce series compensation on the 400kV Line to 40%	Modelled	400kV cable overloads in 2041
	2041	3rd ORM-PAK 400 kV cable	Modelled	ORM-PAK 2 overloads on ORM-PAK 1 outage

Table E-9: Thermal Development Plan for Option 7.2

Reactive Plan : Option 7.2 (400 kV to PAK, Deferred Conversion to 400kV)

Year	Location	Quantity (MVAR)	Static/Dynamic*
2008	OTA	250	S
2009	OTA	100	S
2019	OTA	200	D
2022	HLY	100	S
2023	OTA	100	S
2025	OTA	200	S
2028	HLY	100	S
2033	OTA	200	D
2038	HLY	100	S
2038	OTA	250	S
2042	OTA	400	S
Total		2000	

* Dynamic requirement for transmission contingency into Auckland ONLY

Table E-10: Reactive Plan for Option 7.2

NORTH ISLAND GRID UPGRADE PROJECT – AMENDED PROPOSAL
ATTACHMENT D – TECHNICAL ASSESSMENT OF MODIFIED OPTIONS

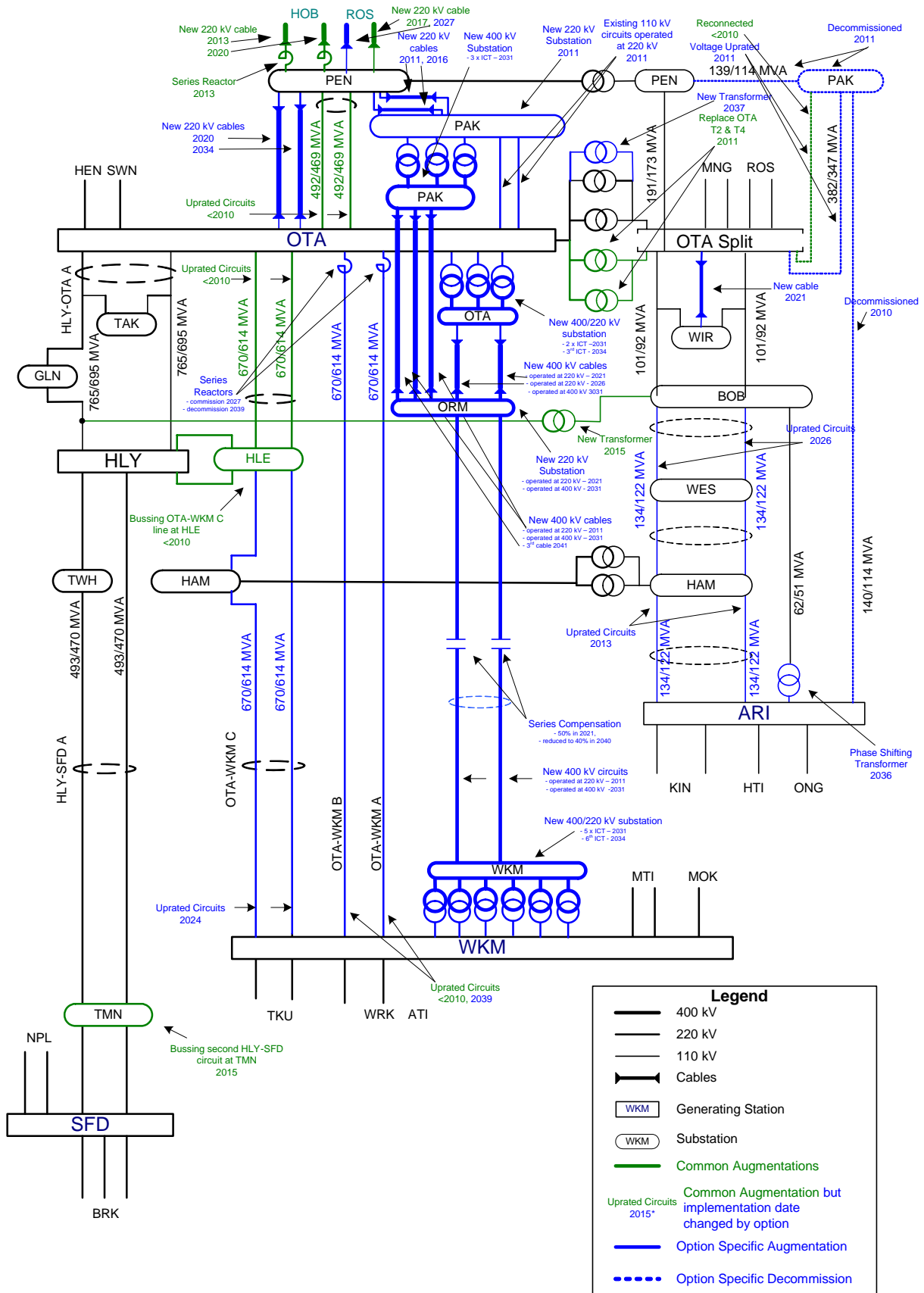

The transfer limit for this option is shown in Figure E-7-10:

Option 7.2 Transfer Limits

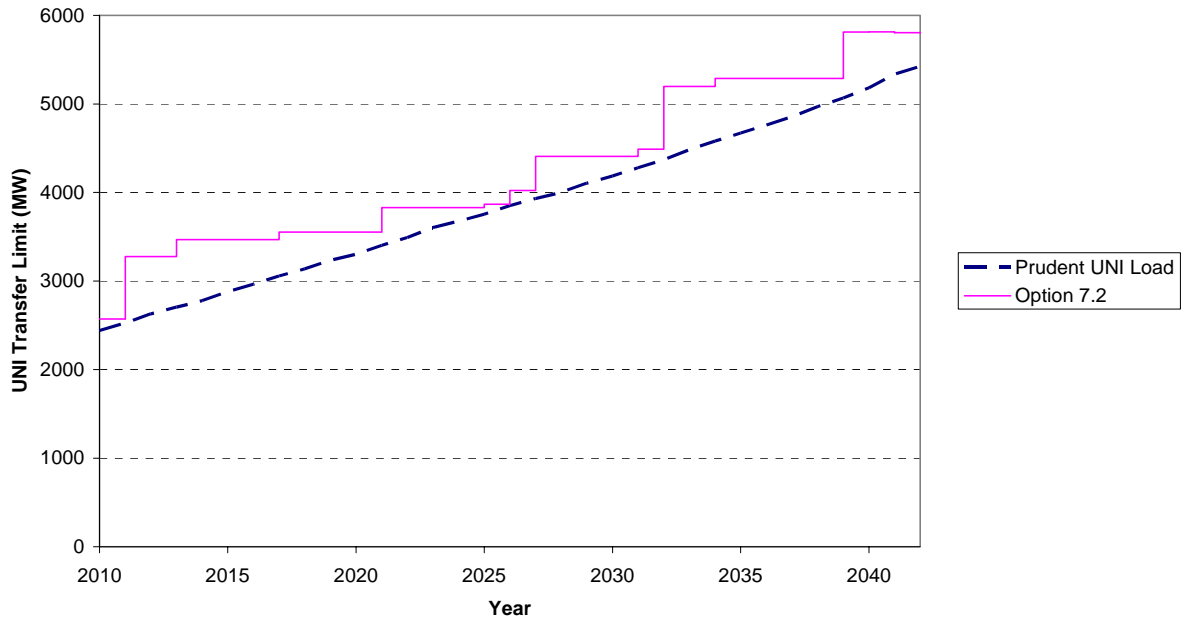

Figure E-7-10: Transfer Limits against forecast demand for Option 7.2

Option 8: 400 kV into Ormiston Road, 220 kV into Pakuranga and Otahuhu (early conversion to 400 kV)

This option considers building a new 400 kV double circuit overhead line between Whakamaru and Ormiston Road. Initially Ormiston Road will be connected to Pakuranga using 220 kV underground cables. Subsequently, additional 220 kV cables will be used to transmit power from the Ormiston Road to Otahuhu. The transmission circuits will initially be operated at 220 kV and converted to operate at 400 kV when required by building 400 kV/220 kV substations at Ormiston Road and Whakamaru. The high capacity 400 kV circuits are then series compensated to increase the transfer capacity into the Upper North Island;

This option considers the 400 kV investment, without augmenting the existing network, apart from those identified as common augmentations listed in Section 5.1..

The 400 kV transmission line will be commissioned and initially operated at 220 kV in 2012. This would increase the transfer limit to the UNI to approximately 3,500 MW.

In 2022, the new line will be upgraded to operate at 400 kV, by building 400 kV sub stations at Otahuhu and Whakamaru. This increases the UNI transfer limit to approximately 4,800 MW.

By 2035, there is a overloading on Hamilton-Whakamaru 220 kV circuit, when a 400 kV circuit is out. At the same time the Otahuhu-Whakamaru A&B circuits are also close to their load limits. As there is still a substantial capacity left on the 400 kV line, it is proposed to install series capacitors on the 400 kV overhead lines up to 50%²⁰. The series capacitors significantly increases the power sharing by the 400 kV line and this increases the transfer limit to approximately 5,100 MW.

Re-conductoring of the Otahuhu and Whakamaru A & B lines to twin goat at 80 degrees, increases the transfer limit above 5,500 MW.

The Thermal and the Reactive development plans for Option 8 are shown in Table E-11 and E-12 and pictorially in Figure E-7-11

Option 8: 400 kV to Ormiston Road (early conversion to 400 kV)				
Transfer Limit (MW)	Year	Augmentation	Type of Project	Reason
2567	2010	Decommission 110 kV Ari-Pak line	GIT	New line uses this line route
3352	2011	2x400 kV circuits from ORM-WKM	GIT	HAM-WKM overloads in HLE-WKM outage
		2x220 kV cables from ORM-PAK	GIT	
		Cable Transition Station at ORM	GIT	

²⁰ No attempt is made to optimise the % of compensation, 50% is chosen as a typical value. The actual value will be confirmed for the preferred option.

Option 8: 400 kV to Ormiston Road (early conversion to 400 kV)				
Transfer Limit (MW)	Year	Augmentation	Type of Project	Reason
		220 kV sub station at PAK	GIT	
		Convert OTA-PAK 110 kV circuits to 220 kV	GIT	
		Install 3x120 MVA supply transformers at PAK	GIT	
		1st PAK-PEN Cable	GIT	
3410	2013	Reconductor ARI-HAM 1 & 2 to Nitrogen 75°C conductors.	Common	110kV ARI-HAM-2 overloads when ARI-HAM-1 is out (in Summer peak demand).
	2017	2nd PAK-PEN cable	GIT	OTA-PEN 5 & 6 overloads in PAK-Pen cable outage
4040	2022	400 kV Sub station at Whakamaru	Modelled	
		400 kV sub station at Ormiston Road	Modelled	
		3x400/220 kV ICTs at Whakamaru	Modelled	HAM-WKM overloads in HLE-WKM
		3x400/220 kV ICTs at Ormiston Rd	Modelled	HAM-WKM overloads in HLE-WKM
		1x110 kV Cable OTA-WIR	Common	OTA-WIR overloads in BOB-WIR-OTA outage
		1x220 kV ORM-OTA cable	Modelled	ORM-PAK 2 cable overloads in ORM-PAK 1 outage
		1x220 kV OTA-PEN cable	Modelled	PAK-PEN 2 overloads in PAK-PEN 1 outage
	2024	2nd ROS 220/110 kV ICT	Common	ROS ICT overloads in OTA ICT outage
4169	2026	2nd ORM-OTA cable	Modelled	ORM-PAK overloads in ORM-PAK outage
		4th ORM 400/220 kV ICT	Modelled	ORM 400/220 kV overloads in ORM 400/220 kV outage
		4th WKM 400/220 kV ICT	Modelled	WKM 400/220 kV overloads in ORM 400/220 kV outage
		Re-conductor HAM-BOB 110 kV circuits to Nitrogen Conductors.	Common	Overload on circuits in contingency in 2027 (Summer High).
	2027	2nd PEN-ROS 220 kV cable	Common	HEN-HEP and OTA T5 overload in PEN-ROS outage

Option 8: 400 kV to Ormiston Road (early conversion to 400 kV)				
Transfer Limit (MW)	Year	Augmentation	Type of Project	Reason
4310	2029	Thermal upgrade HLE-WKM to 80 deg C	Modelled	HAM-WKM overloads in ORM-WKM outage
4565	2030	2x25 ohm series reactors on OTA-WKM A&B	Modelled	OTA-WKM A&B overload in ORM-WKM outage
	2032	3rd ROS ICT	Common	Overload on ROS Interconnector when ROS T1 is out (In contingency) in 2033
		3rd ORM-PAK cable	Modelled	ORM-PAK overloads in ORM-PAK
4809	2033	5th ORM 400/220 kV ICT	Modelled	ORM 400/220 kV overloads in ORM 400/220 kV outage
		5th WKM 400/220 kV ICT	Modelled	WKM 400/220 kV overloads in ORM 400/220 kV outage
		2nd OTA-Pen cable	Modelled	PAK-PEN overloads in PAK-PEN outage
5243	2035	2x50% series capacitors on ORM-WKM circuits	Modelled	HAM-WKM overloads in ORM-WKM outage
	2036	6th 400/220 kV ICT at ORM	Modelled	ORM 400/220 kV overloads in ORM 400/220 kV outage
		6th 400/220 kV ICT at WKM	Modelled	WKM 400/220 kV overloads in ORM 400/220 kV outage
		3rd ORM-OTA cable	Modelled	ORM-PAK overloads in ORM-PAK
	2037	New OTA 220/110 kV ICT in parallel with T3 and T5	Common	ROS ICT overloads in ROS ICT
		1X75 MVA PST on ARI-BOB 110 kV Circuit	Modelled	Reduce overload
5546	2039	Duplex OTA-WKM A&B, remove series reactors on OTA-WKM A&B circuits	Modelled	ORM-WKM overloads in ORM-WKM
5742	2041	Reduce series compensation on ORM-WKM circuits to 40%	Modelled	ORM-WKM overloads in ORM-WKM

Table E-11: Thermal Development Plan for Option 8

Reactive Plan : Option 8 (400 kV to ORM, early conversion to 400 kV)

Year	Location	Quantity (MVAR)	Static/Dynamic*
2008	OTA	250	S
2009	OTA	100	S
2017	OTA	200	S
2019	HLY	100	S
2027	OTA	200	D
2029	HLY	100	S
2029	OTA	100	S
2031	OTA	150	S
2032	OTA	200	D
2033	HLY	100	S
2039	OTA	250	S
2042	OTA	400	S
Total Required		2150	

* Dynamic requirement for transmission contingency into Auckland ONLY

Table E-12: Reactive Plan for Option 8

NORTH ISLAND GRID UPGRADE PROJECT – AMENDED PROPOSAL
ATTACHMENT D – TECHNICAL ASSESSMENT OF MODIFIED OPTIONS

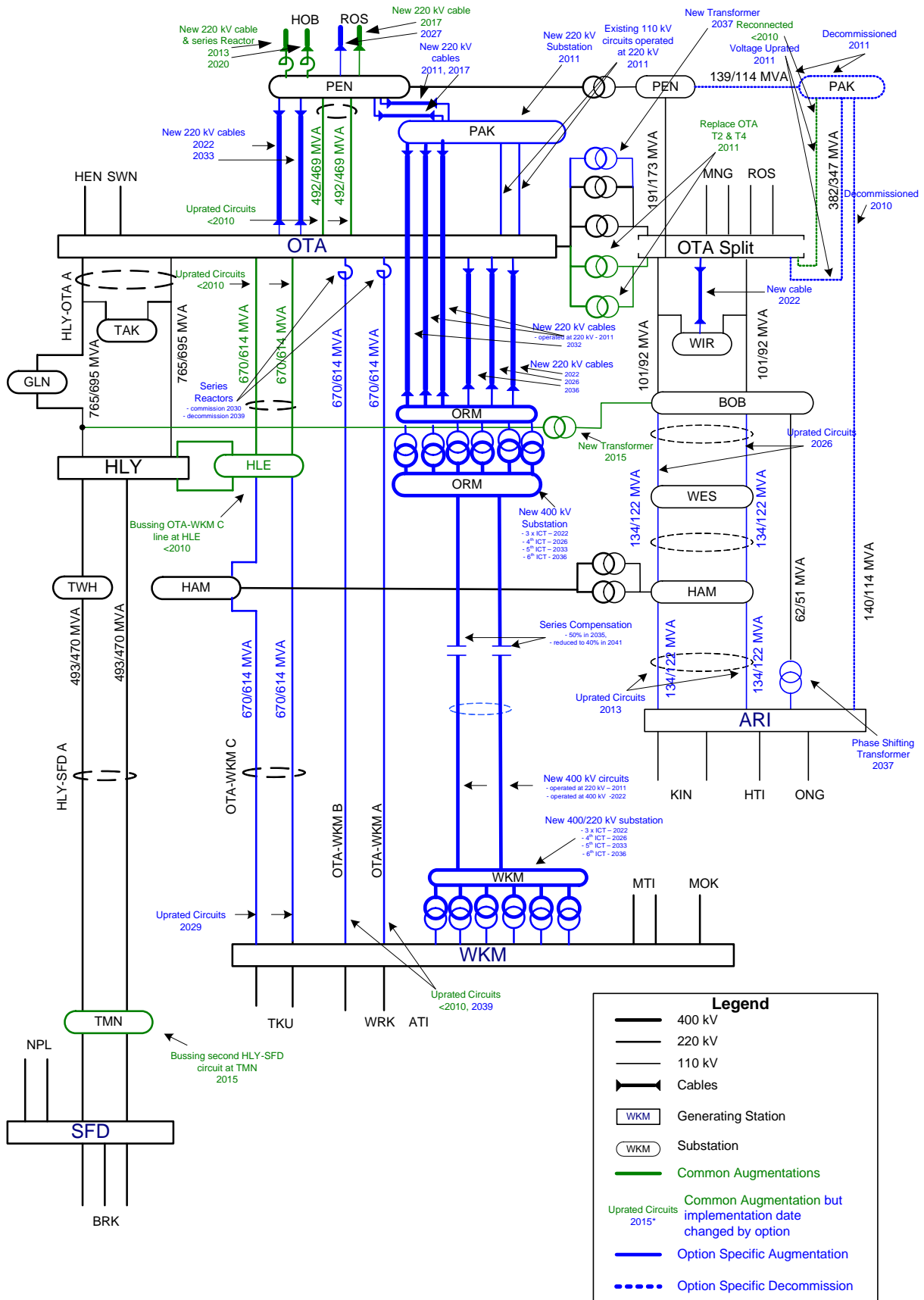

The transfer limit for this option is shown in Figure E-7-12:

Option 8 Transfer Limits

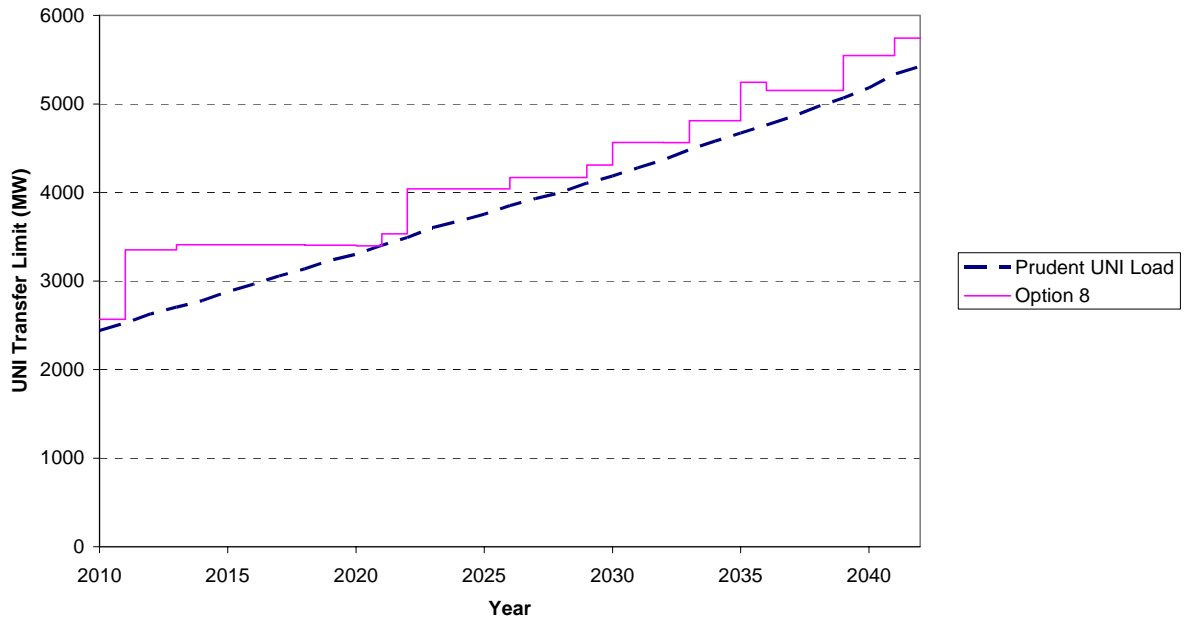

Figure E-7-12: Transfer Limits against forecast demand for Option 8

Appendix G Transmission Losses (Options 5-8)

This section describes the comparison of transmission losses for the alternative transmission options.

The transmission losses are calculated for Winter Peak demand with all the assets in service, including the Otahuhu CCGT. For the purpose of comparison, only the transmission losses associated with the transmission circuits (including 220 kV circuits from Huntly, 110 kV circuits between Arapuni and Otahuhu and the new builds) in the Otahuhu – Whakamaru corridor are shown. The transmission losses in the rest of the transmission system are approximately the same for all the transmission options.

The transmission losses for the three options analysed are shown in Figure F-1. The results shows that while the losses the transmission circuits increases quadratically as the flow through the circuits increases, step reduction in losses could be achieved by investment in transmission

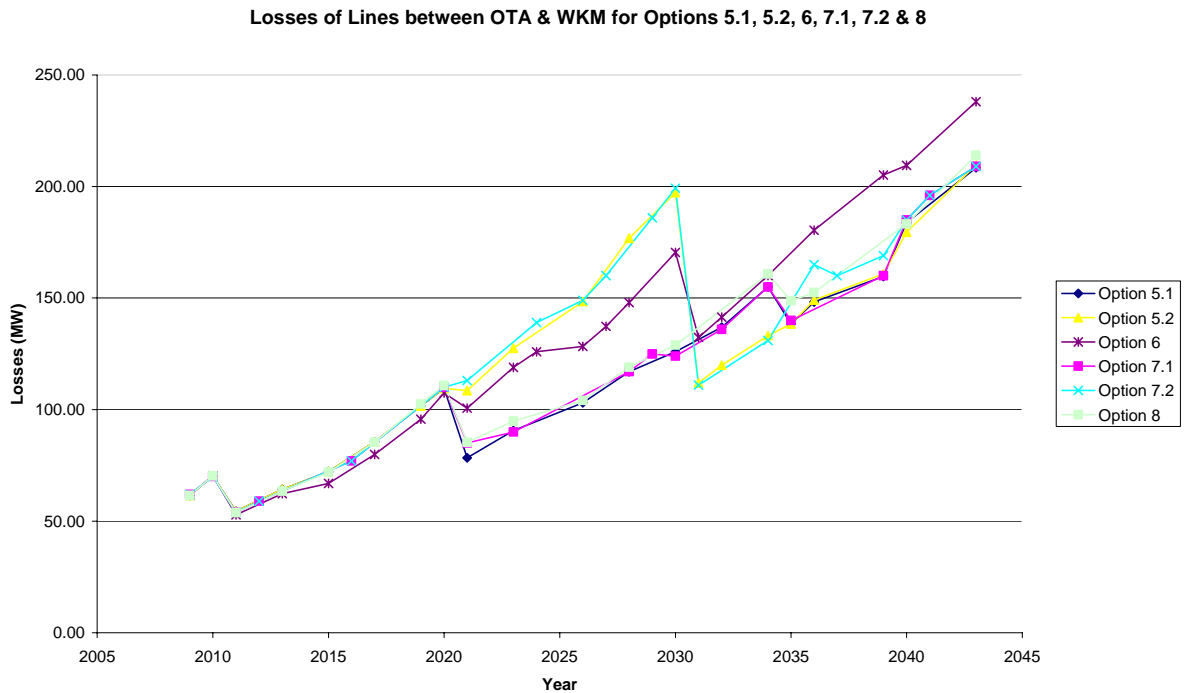

Figure F-1: Transmission Losses for options considered (in Otahuhu-Whakamaru corridor) for winter peak load

Appendix H Reactive Plan (Options 5-8)

The reactive power losses in the power system also increase quadratically as the loading in the transmission circuits are increased. The reactive power losses in the transmission circuits are supplied from the two ends of each transmission circuit. Generally a higher amount of reactive power needs to be supplied from the receiving end compared to the sending end.

The sending end reactive power requirements are assumed to be supplied from the generators at or around Whakamaru. The reactive power available from the generators assumed (as per the generation scenario) is sufficient to provide this reactive requirement. On the other hand, the assumed level of reactive power available in Otahuhu and its vicinity by 2010 is insufficient for supplying the reactive power required from the Otahuhu end for meeting the reactive power losses in the transmission system.

The additional reactive support required at Otahuhu end (and at Huntly where appropriate) for the three transmission options are shown in Figure G-1.

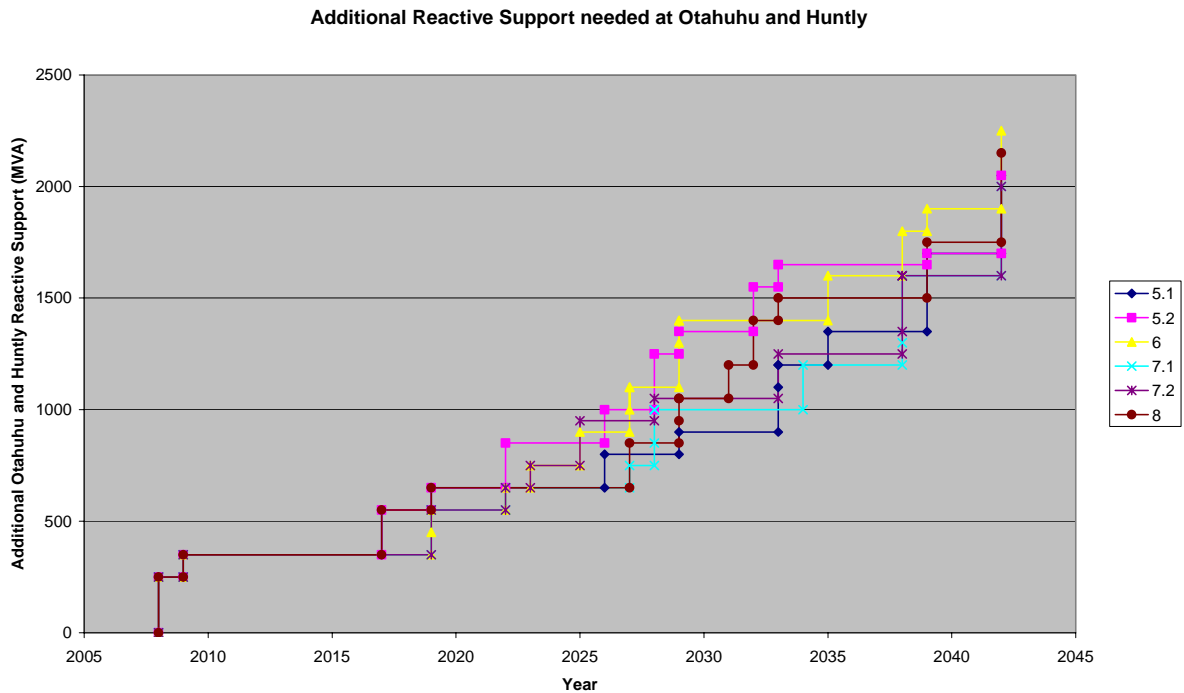

Figure G-1: Reactive Support requirement at Otahuhu and Huntly

Dynamic Reactive Requirement for Transmission line contingency

The reactive power loss in the transmission system between Otahuhu and Whakamaru undergoes a significantly large step change following an outage of a transmission circuit. Hence, in a voltage stability constrained system such as the power system supplying the UNI regions, it is not prudent to rely on post-contingency switching of the capacitor banks for ensuring system stability. It is considered good industry practice to carry sufficient dynamic reserves in the system, pre-contingency, to cater for such events. The dynamic reactive

power reserves can be maintained in the form of reactive power from synchronous generators, synchronous condensers, SVCs and thyristor switched capacitors.

In analysing the dynamic reactive power reserves required in UNI region for power transmission between Otahuhu & Whakamaru, the total reactive power sent into the transmission system from Otahuhu and Whakamaru under the worst contingency is assessed pre and post-contingency. The reactive power difference between the pre and post-contingency situation represents the minimum level of dynamic reactive reserves required at two ends.

By 2010, it is likely that the dynamic reactive support at Otahuhu is supplied from two sources, synchronous condensers (3x33 Mvar + 2x50 Mvar) and the Southdown generator (70 Mvar). The synchronous operation of the generators at leading power factors is less stable compared to their operation at lagging power factors. Therefore the reactive power reserves available from the generating units will be significantly less than the maximum reactive output of the units. Hence the net value of reactive reserves available at Otahuhu, pre-contingency is likely to be approximately 200 Mvar. This estimated presently available dynamic reactive reserves at Otahuhu is also shown in the figure for comparison.

Appendix I Electrical Parameters for preliminary studies (options 5-8)

400kV Double Circuit Line ORM-WKM

Type : Triplex Zebra
Rating 2413/2261 MVA winter/summer
Length 186.5 km
R1 = 4.1776 ohms
X1 = 51.6605 ohms
C1 = 2.4618 microfarads

400kV Cable

Type 2500 sq mm copper
Rating 1188 MVA
With forced Cooling 1986 MVA
R1 = 0.0099 ohms/Km
X1 = 0.1656 ohms/Km
C1 = 0.234 microfarads/Km

220kV Double Circuit Line ORM-WKM

Type Duplex Chukar ACSR-GZ
Rating 1237/1124 MVA winter/summer at 75 deg
Length 186.5 km
R1 = 2.9311 ohms
X1 = 50.8026 ohms
C1 = 2.3499 microfarads

220kV Cable

Type 2500 sq mm copper
Rating 668 MVA
With forced Cooling 1115 MVA (Winter)
R1 = 0.0099 ohms/Km
X1 = 0.1656 ohms/Km
C1 = 0.274 microfarads/Km

Cable Lengths

ORM-OTA : 8.4 Km
ORM-PAK : 8.17 Km
PAK-PEN : 9.1 Km
OTA-PEN : 8.63 Km

220kV Duplex Goat from WKM-OTA

Type Duplex Goat
Rating 670/614 MVA at 80 deg
Length 191 km
R1 = 8.4954 ohms
X1 = 55.068 ohms
C1 = 2.366 microfarads

Series Capacitors on New OTA-WKM 400kV Lines

Maximum line load 2413 MVA (3.475 kA)
Capacitive reactance 25.8302 ohms (50% of line reactance)
Reactive power at full load 936 Mvar

Series Capacitors on New OTA-WKM 220kV Lines

Maximum line load 1237 MVA (3.241 kA)
Capacitive reactance 25.4013 ohms (50% of line reactance)
Reactive power at full load 801 Mvar

400/220 kV Transformer

Rating: 600 MVA
Overload capacity : 116.67%
Voltage ratio: 400/220 kV
Reactance: 10%
R/X: 0.01

110 kV ARI-HAM circuit re-conductor

Conductor : Nitrogen
Length : 47 Km
Rating : 134/126 MVA for Winter/Summer
R1=5.405 ohms
X1=18.19 ohms
C1=0.4465 microfarads

110 kV HAM-BOB circuit re-conductor

Conductor : Nitrogen
Length : 74.5 Km
Rating : 134/126 MVA for Winter/Summer
R1=8.5675 ohms
X1=28.83 ohms
C1=0.7078 microfarads

110 kV PSTs

Rating : 75 MVA
Voltage ratio : 110/110 kV
% Impedance : 10%
R/X = 0.035

Series Reactors on OTA-WKM A&B Circuits

- 20 ohms (Option 2)
- 15 ohms (Option 1)
Current rating: 848 Amps